



HAMBURG CITY COUNCIL AGENDA MARCH 13, 2018

- 1. Call City Council Meeting to Order**
 - **Pledge of Allegiance**

- 2. Public Comment** *(Individuals may address the City Council about any non-agenda item(s) of concern. Speakers must state their name, address, and limit their remarks to three minutes. The City Council may not take official action on these items and may refer the matter to staff for a future report or direct that the matter be scheduled for a future meeting agenda.)*

- 3. Agenda Review (Added Items) and Adoption**

- 4. Consent Agenda** *(NOTICE TO PUBLIC: All those items listed as part of the Consent Agenda will be approved by a single motion, unless a request to discuss one of those items is made prior to that time. Anyone present at the meeting may request an item to be removed from the consent agenda. Please inform the Council when they approve the agenda for this meeting.)*
 - **Approve Resolution Number 2018-04 (CUP for Steve Trebesch)**
 - **Approve Minutes for February 13, 2018**
 - **Approve Payment of Added February Claims (\$7,411.49)**
 - **Approve Payment of March Claims (\$36,465.91)**
 - **Board of Appeal & Equalization Schedule for 2018**
 - **Cash Flow Statements for January 2018**
 - **NYA Times Article (Representative Nash)**
 - **Water Main Break Memo**
 - **Delinquent Utility Bills Report**
 - **Employee Project Lists**

- 5. Hamburg Fire Department Report**
 - **Recognition of Service for Firefighter Eric Schoenbauer (20 Years)**
 - **Fire Chief's Convention**
 - **Fire Board Meeting Review**
 - **2017 Annual Township Report**
 - **City/Township Fire Board Meeting March 12, 2018**
 - **2018 City Contribution to HFDRA (Amend 2018 Budget)**

- 6. Old City Business**
 - **Storm Water Easement (Railroad Street)**
 - **City Name Tags/Shirts**

- 7. New City Business**
 - **Estimates for New Liftstation Pump**
 - **Personnel Committee (2018 Items)**
 - **Medical Leave (Jeremy Gruenhagen)/Vacation (City Employees)**



***HAMBURG CITY COUNCIL AGENDA
MARCH 13, 2018***

8. City Council Reports

- Councilmember Jason Buckentin
- Councilmember Tim Tracy
- Councilmember Scott Feltmann
- Councilmember Steve Trebesch
- Mayor Chris Lund
 - Meeting with State Senator Jensen/Representative Nash

9. Adjourn City Council Meeting



***HAMBURG CITY COUNCIL AGENDA
MARCH 13, 2018***

COMMUNITY HALL & PARK ACTIVITIES

- MARCH**
- 7 – Bongards Creameries
 - 23 – Hamburg Lions Spring Bingo
 - 24 – HFD Retirement Banquet
- APRIL**
- 21 – Wedding Reception

COMMUNITY CENTER (FIRE HALL) ACTIVITIES

- MARCH**
- 5 – Hamburg Lions Board Meeting
 - 5 – HFD Training
 - 12 – Community Center Rental
 - 12 – HFD Training
 - 13 – Hamburg City Council Meeting @ 7:00 PM
 - 13 – Young America Township Meeting
 - 19 – Hamburg Lions Club
 - 20-21 – Wm. Mueller & Sons Safety Meetings
 - 26 – Hamburg Fire Dept. (Relief Association) Meeting
- APRIL**
- 2 – Hamburg Lions Board Meeting
 - 2 – HFD Training
 - 7 – Community Center Rental
 - 8 – Community Center Rental
 - 9 – HFD Training
 - 10 – Hamburg City Council Meeting @ 7:00 PM
 - 10 – Young America Township Meeting
 - 15 – HFDRA Pork Chop Dinner
 - 16 – Hamburg Lions Club Meeting
 - 23 – Central School Board Meeting @ 6:00 PM
 - 30 – Hamburg Fire Dept. (Relief Association) Meeting

**CITY OF HAMBURG, MINNESOTA
RESOLUTION NUMBER 2018-04**

**A RESOLUTION APPROVING A CONDITIONAL USE PERMIT FOR
STEVEN TREBESCH, 335 RAILROAD STREET (PARCEL 45.0282500), FOR ACCESSORY
STRUCTURES ON THE PROPERTY OTHER THAN “PRIVATE GARAGES”**

WHEREAS, Steven Trebesch, 335 Railroad Street (Parcel 45.0282500), has submitted an application to the City of Hamburg for a Conditional Use Permit (CUP) to place two shipping container accessory structures on the property; and

WHEREAS, 335 Railroad Street (Parcel 45.0282500) is zoned B - Downtown Business Mixed Use District according to the City of Hamburg Official Zoning Map and guided for Mixed Use according to the 2030 Land Use map of the City of Hamburg 2030 Comprehensive Plan; and

WHEREAS, Minnesota Statutes, Section 462.3595, establishes the authority of the City of Hamburg to establish standards, requirements and procedures to review and approve conditional uses; and

WHEREAS, the Hamburg Zoning Ordinance, Chapter 160A, Section E, Subdivision 6, Subpart C requires a conditional use permit to be issued by the City in the B District for “Accessory structures other than private garages”; and

WHEREAS, the Hamburg Zoning Ordinance, Chapter 160A, Section E, Subdivision 6, Subpart E establishes front yard structural setbacks at 20 feet, side yard structural setbacks at five feet and rear yard structural setbacks at five feet; and

WHEREAS, Steven Trebesch applied for variances to property setback standards for an 18-foot front yard setback and a 0-foot side yard setback, which were considered after a public hearing was held by the City Council, acting as the Planning Commission, on January 9, 2018, and approved at the February 13, 2018 regular City Council meeting; and

WHEREAS, the Hamburg Zoning Ordinance, Chapter 160A, Section C, Subdivision 6 establishes the procedures for conditional uses and these provisions are incorporated here by reference; and

WHEREAS, on December 12, 2017, and as continued on January 9, 2018, the City Council, acting as the Planning Commission, held a public hearing and considered the application for the CUP to place accessory structures other than private garages at 335 Railroad Street (Parcel 45.0282500); and

WHEREAS, based upon the review of the Hamburg Zoning Ordinance and the comments received at the public hearing, the Planning Commission finds that the proposed application and supporting information for the CUP to place accessory structures other than private garages at 335 Railroad Street (Parcel 45.0282500) meets the requirements of the Hamburg Zoning



Ordinance, Chapter 160A, Section F, Subdivision 2, and Subdivision 4 Subpart A, in accordance with the following Findings:

1. All of the standards contained in this subdivision and the standards of this ordinance will be met, as modified by the variance,
2. The use is consistent with goals and policies of the Comprehensive Plan,
3. The use does not have an undue adverse impact on governmental facilities, utilities, services or existing or proposed improvements,
4. The use will not negatively impact the use and enjoyment of other properties and uses in the immediate vicinity,
5. The use will not impede planned development and improvement of the property, including the provision of municipal utilities, stormwater drainage, roadways and access; or the planned development of surrounding properties in accordance with the Comprehensive Plan and the standards of this ordinance, and
6. The use does not have an undue adverse impact on the public health, safety or welfare.

THEREFORE, BE IT RESOLVED, the City Council hereby approves the CUP for Steven Trebesch to place accessory structures other than private garages at 335 Railroad Street (Parcel 45.0282500), subject to the following conditions:

1. A maximum of two accessory structures shall be allowed on the property.
2. The front yard setback shall be a minimum of eighteen (18), the side yard setback shall be a minimum of zero (0) feet and the rear yard setback shall be a minimum of five (5) feet.
3. The variances granted and conditional use permit must be recorded on the property, as required by law, by the applicant and evidence of the recordings be submitted to the City of Hamburg; otherwise, the variance and CUP shall be consider null and void.

I CERTIFY THAT the above resolution (Resolution 2018-04) was adopted by the City Council of Hamburg, Carver County, Minnesota this 13th day of February, 2018.

Chris Lund, Mayor

ATTEST:

Jeremy Gruenhagen, City Clerk/Treasurer



“The City of Hamburg is an Equal Opportunity Employer and Provider.”



HAMBURG CITY COUNCIL MEETING FEBRUARY 13, 2018

Mayor Chris Lund called the Hamburg City Council Meeting to order at 7:00 p.m. In attendance were: Council members Scott Feltmann, Steve Trebesch, Tim Tracy and Jason Buckentin. Representative Jim Nash, Residents Mike Stuewe, Jake Trebesch, Aaron Prim, Ben & Kelli Schlagel, and Joe Butler.

Agenda Review (Added Items) and Adoption

- December Added Claims List - Consent Agenda
- Letter from Hamburg resident Richard Odoms – New City Business

MOTION: Councilman Steve Trebesch moved to approve the Agenda as amended. Seconded by Councilman Jason Buckentin. Motion was unanimously approved. All Council Members were present.

Consent Agenda

- Approve Minutes for January 9, 2018
- Approve Payment of September 2017 Added Claims (\$500)
- Approve Payment of November 2017 Added Claims (\$80.13)
- Approve Payment of December 2017 Added Claims (\$80.00)
- Approve Payment of January 2018 Added Claims (\$21,602.90)
- Approve Payment of February Claims (\$18,887.15)
- Approve Lawful Gambling Permit for Hamburg Lions (March 23, 2018)
- Approve Temporary On-Sale Liquor License from Hamburg Lions Club for March 23, 2018
- Approve Renewal of Consumption & Display Permit (Community Hall)
- Approve Pay Equity Report
- Cash Flow Statements for November/December 2017
- Delinquent Utility Bills Report
- Employee Project Lists
- Mediacom Letter (Local Broadcast Station Surcharge)
- City Offices Closed February 19, 2018 for Presidents Day

MOTION: Councilman Jason Buckentin moved to approve the Consent Agenda. Seconded by Councilman Steve Trebesch. Motion was unanimously approved. All Council Members were present.

State Representative Jim Nash (District 47A)

- 2018 State Legislation/City Concerns
 - Water Tower
- 2018 Legislative Conference (LMC)
 - Representative Nash updated the council on transportation topics (Roads, Bridges, Light Rail etc.) He listened to Council's concerns regarding funding the new water tower that Hamburg needs. He invited residents to see him at the Capitol over the next 13 weeks.



HAMBURG CITY COUNCIL MEETING
FEBRUARY 13, 2018

Mike Stuewe

- Proposed Development (Parcel 11.0280200)
 - Land survey came out to be 3.6 acres where Mr. Stuewe is looking at building 5 double units. Several Hamburg Residents attended and voiced concerns regarding the project. Mr. Stuewe is to provide the Council with his survey once he receives it and a rough drawing with a layout concept.

Old City Business

- MN Community Awareness Emergency Response (CoRE Meeting)
- Conditional Use Permit/Variance Request (Steve Trebesch)
Storage Containers
MOTION: Councilman Scott Feltmann moved to approve the Conditional Use Permit and Variance Request. Seconded by Councilman Tim Tracy. Motion was approved with Councilman Steve Trebesch abstaining. All Council Members were present.
- Storm Water Easement (Railroad Street)
 - Lawyer's from both entities will discuss the easement guidelines.

New City Business

- Letter from Richard Odoms (Retention of City Information)
- Norwood-Young America Guide
MOTION: Councilman Steve Trebesch moved to approve a ¼ page ad of the Hamburg Hall in the NYA Guide with a new picture and highlight upgrades. Seconded by Councilman Scott Feltmann. Motion was unanimously approved. All Council Members were present.
- Urban Land Institute Membership
MOTION: Councilman Scott Feltmann moved to approve the Associate Member level with the ULI. Seconded by Councilman Steve Trebesch. Motion was unanimously approved. All Council Members were present.
- Park Rental Fee (Fee for Additional Day)
 - Council was in agreement that additional park rental dates would be at the regular daily rate.
- Personnel Committee (2018 Items)
 - Review City Ordinances/Zoning Ordinance
- Set Public Hearing for the Comp. Plan at 6:30 p.m. on May 8, 2018



***HAMBURG CITY COUNCIL MEETING
FEBRUARY 13, 2018***

City Council Reports

- Councilmember Steve Trebesch – New City shirts? Yes
- Mayor Chris Lund
 - SW Corridor Transportation Coalition Meeting
 - Carver County Leaders Meeting
 - Would like magnetic name tags for Council and Staff

MOTION: Councilman Steve Trebesch moved to adjourn the Hamburg City Council Meeting at 8:38 p.m. Seconded by Councilman Jason Buckentin. Motion was unanimously approved. All Council Members were present.

Submitted by:

Tamara Bracht
Deputy Clerk

2018 February Claims List

CHECK #	VENDOR	FUND	CLAIM DESCRIPTION	AMOUNT	APPROVED	
ACH	EFTPS	Divided	Fed, Social Security, MC - January 2018	\$2,730.24	2/13/2018	
ACH	PERA	Divided	PERA Withholding - January 2018	\$735.01	2/13/2018	\$ (0.03)
ACH	PERA	Divided	PERA Withholding - February 2018	\$433.75	2/13/2018	
ACH	MN Dept of Revenue	Divided	January 2018 State Withholding Tax Payment	\$463.00	2/13/2018	
ACH	Optum Bank	General Gov't	HSA Participant Fee for 4th Qtr 2017	\$22.50	2/13/2018	
ACH	HealthPartners	Divided	Health Insurance for February 2018	\$2,958.95	2/13/2018	
ACH	MN Dept. of Labor & Industry	Public Safety	Building Permit Surcharge Report (4th Qtr. 2017)	\$4.44	2/13/2018	
ACH	Greg Schultz	Divided	Wages 1-15-18 to 1-28-18	\$1,666.43	2/13/2018	
ACH	Tamara Bracht	Divided	Wages 1-15-18 to 1-28-18	\$599.07	2/13/2018	
ACH	Jeremy Gruenhagen	Divided	February Wages	\$1,843.87	2/13/2018	
ACH	Greg Schultz	Divided	Wages 1-29-18 to 2-11-18	\$1,645.08	3/13/2018	
ACH	Tamara Bracht	Divided	Wages 1-29-18 to 2-11-18	\$616.96	3/13/2018	
ACH	Google	General Gov't	Email Account Service for January 2018	\$80.00	3/13/2018	
ACH	AT&T	General Gov't	Cell Phone Payment (February)	\$28.85	3/13/2018	
Debit Card	Best Name Badges	General Gov't	Magnetic Name Badges for Council and Staff	\$84.60	3/13/2018	
Debit Card	UPS	Enterprise	Overnighted Water Samples	\$10.46	3/13/2018	
Debit Card	Amazon	General Gov't	2 Tape Dispensers, Microphone with Tripod, Laminator with Pouches	\$115.77	2/13/2018	
Debit Card	AMEM	Public Safety (FD)	2018 AMEM Membership	\$130.00	2/13/2018	
19002	Scott Anderson	Public Safety (FD)	Reimbursement for a Lightbulb for Rescue II	\$15.99	2/13/2018	
19003	Alcohol & Gambling Enforcement	Hall	Consumption & Display Permit (Renewal Date - April 1)	\$250.00	2/13/2018	
19004	Carver County	General Gov't	Audit 2017 Year End Tax District Verification	\$150.00	2/13/2018	
19005	CarverLink	Divided	Phone Service (2/1/18 - 2/28/18)	\$119.05	2/13/2018	
19006	Champion Window Company	Public Safety (FD)	Reimbursement for Permit Overpayment	\$1.75	2/13/2018	
19007	Floyd Total Security	Water	Base Alarm Monitoring for WWTP (3-3-18 to 6-2-18)	\$86.85	2/13/2018	
19008	G & K Services	Divided	Cleaning Supplies - Towels, Mops, Rags, Garbage Liners	\$66.52	2/13/2018	
19009	Melchert-Hubert-Sjodin	General Gov't	Correspondence To & From Regarding Prescriptive Easements	\$60.00	2/13/2018	
19010	Van Iwaarden	General Gov't	Dec. 31, 2017 GASB 68 Pension Accounting Using the "Lookback" Method	\$2,000.00	2/13/2018	
19011	Viking Bottling Company	Hall	Pop for Hall Upstairs 1-31-18	\$495.00	2/13/2018	
19012	W.W.O.T.A.	Divided	Water/Wastewater Training & Assistance for January 2018	\$675.00	2/13/2018	
19013	Wm. Mueller & Sons, Inc.	Public Works (Streets)	Plow & Sanding, Fuel for City Vehicles, Bucket of Red Rock	\$1,768.75	2/13/2018	
19014	Xcel Energy Inc.	Water	Electrical/Natural Gas Service 1-3-18 to 2-3-18	\$1,495.18	2/13/2018	
19015	Business Essentials	General Gov't	Office Supplies: Envelopes, Open/Close Sign, Vis-à-Vis Markers, Dividers	\$73.61	3/13/2018	
19016	CarQuest	Public Safety (FD)	Halogen Light and Back-up Alarm for Rescue II	\$42.98	3/13/2018	
19017	Core & Main	Divided	Annual Support Contract 4-12-18 to 4-11-19	\$2,160.00	3/13/2018	
19018	MN Dept. of Health	Enterprise	Drinking Water Protection 1st Quarter 2018 (212 Connections)	\$337.00	3/13/2018	
19019	MNSPECT	Public Safety (FD)	Permit Fee's for 145 Jacob (Windows), 630 Kim (Furnace) includes a 1.25	\$68.75	3/13/2018	
19020	MES (Municipal Emergency Services)	Public Safety (FD)	"C" Size Batteries for Air Packs	\$36.85	3/13/2018	
19021	Plunkett's Pest Control	General Gov't	City Hall & FD General Inspection 2-07-18	\$39.37	3/13/2018	
19022	Xcel Energy Inc.	Divided	Electrical/Natural Gas Services 1/03/18 to 2/3/18	\$1,751.53	3/13/2018	
Transfer	State Bank of Hamburg	General Gov't	Transfer from General Fund to JPBC	\$435.48	3/13/2018	
				\$26,298.64		
			February Claims	\$18,887.15	2/13/2018	
			Added February Claims	\$7,411.49	3/13/2018	
			Total February Claims	\$26,298.64		

2018 March Claims List

CHECK #	VENDOR	FUND	CLAIM DESCRIPTION	AMOUNT	APPROVED
ACH	EFTPS	Divided	Fed, Social Security, MC - February 2018	\$2,540.74	3/13/2018
ACH	PERA	Divided	PERA Withholding - February 2018	\$422.72	3/13/2018
ACH	PERA	Divided	PERA Withholding - February 2018	\$707.07	3/13/2018
ACH	PERA	Divided	PERA Withholding - March 2018	\$422.95	3/13/2018
ACH	MN Dept. of Revenue	Divided	February 2018 State Withholding Tax Payment	\$468.00	3/13/2018
ACH	HealthPartners	Divided	Health Insurance for February 2018	\$2,958.95	3/13/2018
ACH	Jeremy Gruenhagen	Divided	February Wages	\$1,843.86	3/13/2018
ACH	Greg Schultz	Divided	Wages 2-12-18 to 2-25-18	\$1,732.66	3/13/2018
ACH	Tamara Bracht	Divided	Wages 2-12-18 to 2-25-18	\$539.93	3/13/2018
Debit Card	Hamburg Post Office	Divided	3 Rolls of Postcard Stamps for February Water Bills \$35.00 per roll	\$105.00	3/13/2018
Debit Card	Idrive	General Gov't	Computer Data Back Up Program with a 2 Year Plan	\$149.25	3/13/2018
19023	Melvin Sprengeler	Divided	Wages 2-12-18 to 2-25-18	\$92.35	3/13/2018
19024	Scott Anderson	Public Safety (FD)	Reimbursement for AA Batteries	\$9.37	3/13/2018
19025	Abdo, Eick & Meyers LLP	General Gov't	Certified Audit Services for the Year Ended 2017	\$11,000.00	3/13/2018
19026	Carver County (CarverLink)	General Gov't	Telepohne/Internet Services 3-1-18 to 3-31-18	\$119.28	3/13/2018
19027	CenturyLink	Divided	Phone Service (2/18/18 - 3/17/18)	\$179.59	3/13/2018
19028	Core & Main	Water	51 Radio Reads, 12 Touch Pads, 12 Meters	\$7,995.00	3/13/2018
19029	ECM Publishing	Hall	Wedding Guide Advertisement (New Hall Picture)	\$170.00	3/13/2018
19030	G & K Services (Cintas)	Divided	Cleaning Supplies - Towels, Mops, Rags, Garbage Liners	\$66.52	3/13/2018
19031	Home Solutions	Public Safety (FD)	(3) 4 Packs of C Batteries for Air Packs	\$26.97	3/13/2018
19032	Joe Weverka	Public Safety (FD)	Reimbursement for Mileage to N. Mankato Fire School Class - 98 Miles	\$53.41	3/13/2018
19033	League of MN Cities	General Gov't	2018 Legislative Conference for Cities - St. Paul on 3-22-18	\$99.00	3/13/2018
19034	Melchert-Hubert-Sjodin	General Gov't	Correspondence from and to Jeremy regarding Odoms Letter to the Ci	\$52.50	3/13/2018
19035	Menards	Divided	Ice Melt, Dawn Dish Soap, Water Softner Pellets	\$28.51	3/13/2018
19036	MNSPECT	Public Safety (FD)	Permit Fee for Re-Window at 822 William & 662 Park	\$70.00	3/13/2018
19037	Quill	General Gov't	1 Carton of Copy Paper	\$62.79	3/13/2018
19038	Tamara Bracht	General Gov't	Reimbursement for Newsletter Postage	\$69.06	3/13/2018
19039	US Postal Service	General Gov't	2018 Post Office Box Rental Fee (Box 248)	\$92.00	3/13/2018
19040	Viking Bottling Company	Hall	Pop for Hall on 2-2-18 with a Reimbursement for Leaking Root Beer &	\$182.00	3/13/2018
19041	W.W.O.T.A.	Divided	Water/Wastewater Training & Assistance for February 2018	\$540.00	3/13/2018
19042	Wm. Mueller & Sons, Inc.	Public Works	Truck & Sander, Plow with Blade & Wing, Fuel for City Vehicles, Red R	\$2,209.34	3/13/2018
19043	Xcel Energy	Divided	Electricity/Natural Gas Services (2/3/18 - 3/5/18)	\$1,466.46	3/13/2018
				\$36,475.28	

FINAL

BOARD OF APPEAL & EQUALIZATION SCHEDULE
FOR 2018

April	16	Monday	6:00	p.m.	San Francisco Township
May	1	Tuesday	6:00	p.m.	Young America Township
	7	Monday	6:00	p.m.	Watertown Township
	14	Monday	6:00	p.m.	Dahlgren Township

Open Book Meeting at the Carver County Assessor's Office

April 23- April 27	8:00 a.m. – 4:30 p.m.
Chaska City	Watertown City
Norwood Young America	Chanhassen
Hamburg	New Germany
Carver	Mayer
Victoria	Waconia City
Cologne	Benton Township
Hancock Township	Laketown Township
Camden Township	Waconia Township
Hollywood Township	

Tuesday, June 12, 2018 at 9AM County Board of Appeal & Equalization

State Rep. talks roads in Hamburg

BY COLE WHITE
cole.white@ecm-inc.com

State Rep. Jim Nash attended the Hamburg City Council meeting on Feb. 12 to highlight his legislative priorities for the coming session as well as seek input from the community.

"I do enjoy stopping in to the cities I serve to chat about things but also to give you an update as to where things are in the session," Nash said.

Nash went on to note that the previous session had invested heavily in roads and bridges, a topic that would dominate the conversation - particularly in regards to the more rural areas that he represents. Nash said he pushed hard for that inclu-

sion, explaining that previously funding was lacking for cities smaller than 5,000 people. He said that cities larger than 5,000 people received the funding that many smaller towns were denied, and that as a legislator, he fought for their inclusion.

"I'm glad to say we have made it something that is ongoing," Nash said.

Communities such as Hamburg, as well as other small towns, will receive a state stipend based on road miles to go toward infrastructure repairs.

"An additional thing that happened this year - since we are surrounded by farms and live near townships - we also fought for townships to get the same payment," Nash said. "We all know township roads wear down the same way big city roads do."

Nash continued to discuss the importance of maintaining infrastructure, particularly for smaller communities - both at the moment and looking ahead.

"That was something we pushed very hard for. And I've heard from mayors and council members that is really something that props up your budget, particularly as it comes to maintaining your streets. And it's going to be a stark reality in a couple of weeks when we start to thaw," Nash said. "So that was a big deal."

Nash went on to address efforts he personally undertook, dedicating a large portion of his presentation to describing his involvement in changing the funding for

See NASH/ Page 7

NASH from page 1

the Southwest Light Rail. His contribution, Nash said, was to remove part of the transportation bill that would have had taxpayers covering costs of the railway.

"I realized that even though we didn't appropriate the money the state was still going to be on the hook for maintaining and operating and engineering, and I thought, 'there's a great idea for a bill,'" Nash said. He added that he drafted the bill so that the state will be "out of the business" of paying for the light rail line.

"I've never had to fight for anything as hard as that. But, here's the deal - we were able to get the Minnesota taxpayer off the

hook for that," Nash said. "And got the Minnesota taxpayer off the hook for about \$58-62 million a year."

"That was a lot of fun, I have to admit, making that change to the Met Council budget, because for the people that I serve, it's hard to get a meeting let alone a call back from the Met Council and they impact housing in communities," Nash said. "It's my idea that if they are going to be invasive then I am also going to make sure that the people that I represent aren't on the hook for an experiment that thus far isn't really working."

Nash ended his presentation to the council with a look ahead to the current legislative session. He stressed that he would continue to pursue and push for more funding for infrastructure, such as roads, bridges and water towers, while noting it is still not clear if there will be a bonding bill.

"Most of you that have followed me know I'm not a huge fan of bonding," Nash said. "But it is a practical reality that we do have fixed assets that we have to make sure we get maintained."

He added that he is working closely to put more money into the Public Fa-

cilities Authority, which would benefit towns such as Hamburg, which he said he was sure would qualify for grants.

Nash ended the presentation by inviting the council as well as audience to the Capitol.

"It's your Capitol," Nash said.

He stressed that it makes an impact for citizens to attend and speak on behalf of issues that affect them personally.

"It just means more, it means a lot to other members," Nash said, adding that it's important for constituents to show they are "real people in real cities."



Jeremy Gruenhagen <cityadmin@cityofhamburgmn.com>

Main break

Jeremy Gruenhagen <cityadmin@cityofhamburgmn.com>
To: Chris Lund <clund@cityofhamburgmn.com>

Mon, Mar 12, 2018 at 11:24 AM

Timeline for Water Main Break

- Greg was notified of Water Main Leak on February 18th by Mr. Tollefson. Greg checked the leak at Mr. Tollefson's house and found the leak was following his water line into his basement. A sump pump was set up to pipe the water outside for there was no drain in the basement.
- Greg called Water Conservation to locate the leak on February 19th. The leak was located in the alley West of Mr. Tollefson's house, City water main.
- Greg called Hennen's Excavation on February 20th and called in locates, which take 2-3 days to complete. Hennen's was scheduled to come out the week of the 26th but was delayed due to weather and a project they were completing.
- Greg had to call and get the area relocated by Gopher State due to the delay, therefore, delaying the project further. Locates are only valid for 7 days and then must be relocated. Greg called in locates on March 6th to locate the area for a start date of March 9th.
- The leak was repaired on March 9th.
- Over the course of this period, Mr. Tollefson was in contact with Greg via Text messages and Mr. Tollefson also stoped in City Offices over this time period.

Jeremy Gruenhagen

City Clerk-Treasurer
P.O. Box 248
181 Broadway Avenue
Hamburg, MN 55339
[952-467-3232](tel:952-467-3232)



On Fri, Mar 9, 2018 at 12:25 PM, Chris Lund <clund@cityofhamburgmn.com> wrote:

[Quoted text hidden]

FEBRUARY 2018 DELINQUENCY REPORT

Updated Balances	payments	BALANCE (current + over due)	CURRENT		Total \$ overdue	30 days over			Account #
			FEB	JAN		1 Per. Overdue	2 Per. Overdue	3 Per. Overdue	
\$0.00	\$237.23	\$237.23	\$109.90	\$127.33	\$127.33				01-00002470-02-4
\$88.22	\$400.00	\$488.22	\$127.49	\$360.73	\$204.22	\$156.51			01-00002490-00-4
\$0.00	\$251.60	\$251.60	\$127.49	\$124.11	\$124.11				01-00002611-00-5
\$0.00	\$225.22	\$225.22	\$117.23	\$107.99	\$107.99				01-00003612-00-5
\$160.78	\$0.00	\$160.78	\$80.58	\$80.20	\$76.15	\$4.05			01-00003619-00-2
\$217.43	\$0.00	\$217.43	\$142.15	\$75.28	\$75.28				01-00005360-00-5
\$123.10	\$201.49	\$324.59	\$123.10	\$201.49	\$101.10	\$100.39			01-00005421-00-1
\$110.04	\$104.03	\$214.07	\$99.64	\$114.43	\$114.43				01-00006180-00-6
\$441.46	\$0.00	\$441.46	\$131.89	\$309.57	\$309.57				01-00006190-01-2
\$295.55	\$0.00	\$295.55	\$158.28	\$137.27	\$137.27				01-00007625-00-7
\$76.19	\$70.20	\$146.39	\$76.19	\$70.20	\$70.20				01-00008430-00-0
\$190.88	\$0.00	\$190.88	\$91.28	\$99.60	\$99.60				01-00009451-00-6
\$140.24	\$127.49	\$267.73	\$127.49	\$140.24	\$140.24				01-00010170-00-2
\$0.00	\$105.20	\$105.20	\$98.17	\$7.03	\$7.03				01-00010171-00-3
\$513.96	\$0.00	\$513.96	\$128.96	\$385.00	\$167.08	\$125.98	\$91.94		01-00010191-00-9
(\$0.54)	\$150.00	\$149.46	\$74.71	\$74.75	\$74.75				01-00011750-00-7
\$154.90	\$127.49	\$282.39	\$142.15	\$140.24	\$140.24				01-00011846-00-7
\$217.16	\$0.00	\$217.16	\$101.10	\$116.06	\$116.06				01-00011890-00-6
\$640.27	\$0.00	\$640.27	\$187.60	\$452.67	\$313.79	\$138.88			01-00015811-00-9
\$260.68	\$0.00	\$260.68	\$133.35	\$127.33	\$127.33				01-00015822-00-3
\$291.21	\$300.00	\$591.21	\$206.65	\$384.56	\$240.14	\$144.42			01-00016604-00-4
\$284.32	\$0.00	\$284.32	\$127.49	\$156.83	\$141.76	\$15.07			01-00017613-00-5
\$133.97	\$112.83	\$246.80	\$112.83	\$133.97	\$125.01	\$8.96			01-00017615-00-7
\$291.06	\$137.00	\$428.06	\$126.03	\$302.03	\$152.02	\$150.01			01-00017621-00-6
\$4,630.88	\$2,549.78	\$8,190.40	\$3,508.56	\$4,681.84	\$3,745.63	\$844.27	\$91.94		

Activity/Project List Deputy Clerk February - March, 2018

Date	Activity	Date	Outcome
2/12/2018			
2/13/2018	prepared for Council Meeting, accepted a donation of stuffed animals for the FD		
2/14/2018	Happy Valentines Day! I mailed out payments for our city bills and typed up the meeting minutes. I helped direct a semi-driver to Farm Supply in Green Isle.		
2/20/2018	Assisted Auditors when needed, interacted face-to-face residents		
2/22/2018	Finished meeting minutes		
3/1/2018	Sent out Water bills		
3/2/2018	Mailed out the Newsletter		
March 5-9	Worked on I & I water project mailings, scheduling. Took calls to sign up for Election Judges and Lead Testing		
3/9/2018	Fielded phone calls regarding the water main shut off on Maria Avenue		Water was back on by 2:30ish
3/12/2018	Entered bills, updated Claims. Entered water payments, entered receipts in QB		

Fire Chief

Date	Activity/Project	Due Date	Update
	Ice Rink	Is setup and open.	Fire Dept will keep flooding in small sheets as

HAMBURG FIRE DEPARTMENT

181 BROADWAY AVE. HAMBURG, MN 55339

2017 ANNUAL TOWNSHIP REPORT

MARCH 13, 2018

JUSTIN BUCKENTIN: CHIEF 1

STEVE BUCKENTIN: CHIEF 2

CHRIS PETZ: CHIEF 3

JARED MACKENTHUN: CAPTAIN 1

STEVEN SIEWERT: CAPTAIN 2

JAYSON HANSEN: SECRETARY

23 Current Members

Relief Association Contribution	\$26,909.00
Fire Department Salaries	\$11,340.52
Mileage	\$1,738.88
Gas & Oil	\$2,606.56
Office Supplies	\$1,725.42
Repairs & Maint (pagers & radios)	\$765.60
Repairs & Maint (equipment)	\$5,467.81
Insurance	\$3,859.00
Rescue Reserve	\$886.54
Utilities (gas, electric)	\$3,527.91
Convention Expenses	\$1,206.22
Training Expenses	\$3,079.20
Fire Equipment	\$39,212.55
Miscellaneous	\$2,186.97
Supplies & Parts	\$4,344.50
Total Operating Expenses	\$106,231.26
Young America Township Fees	\$13,650.00
Washington Lake Township Fees	\$12,900.00
Grants/Donations/Other	\$16,945.00
2% State Aid	\$15,724.02

2017 TOTAL HAMBURG FIRE DEPARTMENT CALLS

CITY OF HAMBURG

RESPONSES: 21

YOUNG AMERICA TOWNSHIP

RESPONSES: 8

WASHINGTON LAKE TOWNSHIP

RESPONSES: 9

MUTUAL AID RESPONSES

RESPONSES: 3

HOURS

1,145 Training Hours

364 Meeting Hours

41 Total Responses

665.45 Call Response Hours

YOUNG AMERICA TOWNSHIP

2016 PAYMENT

1. Township Payment
-91 units@ $\$150/\text{unit}=\$13,650$

2017 PAYMENT

1. Township Payment
-91 units@ $\$150/\text{unit}=\$13,650$

2018 PAYMENT

1. Township Payment
-91 units@ $\$150/\text{unit}=\$13,650$

WASHINGTON LAKE TOWNSHIP

2016 PAYMENT

1. Township Payment
-86 units@ $\$150/\text{unit}=\$12,900$

2017 PAYMENT

1. Township Payment
-86 units@ $\$150/\text{unit}=\$12,900$

2018 PAYMENT

1. Township Payment
-88 units@ $\$150/\text{unit}=\$13,200$



Jeremy Gruenhagen <cityadmin@cityofhamburgmn.com>

Hamburg Fire Relief Association

Karen Morales <Karen.Morales@osa.state.mn.us>

Tue, Feb 6, 2018 at 11:25 AM

To: "c425conquest@gmail.com" <c425conquest@gmail.com>

Cc: "cityadmin@cityofhamburgmn.com" <cityadmin@cityofhamburgmn.com>, "kenvcpa@newulmtel.net" <kenvcpa@newulmtel.net>

Dear Mr. Anderson,

Thank you for submitting the 2017 Schedule Form (SC-17) for the Hamburg Fire Relief Association. As a courtesy, we conducted a preliminary review of the 2017 form.

Revisions were made to the deferred member section of the SC-17. Because the SC-17 form contains not public data, I will be sharing the revised form with you using a secure delivery method. Soon, you should receive an email with a link from me inviting you to share the "Hamburg Fire Relief Association" folder. When you click on the link, you will be taken to a web page to register. Your User ID will be set to your email address. Enter your name and a password of your choosing.

After you have submitted your information by clicking the Register button, you should receive a confirmation email with a link to sign in and access the SC-17 form saved in the "Hamburg Fire Relief Association" folder.

The revisions to the form resulted in the required municipal contribution for 2018 to increase to \$14,302. Please obtain signatures on the revised form and submit the signed copy to my attention at the Office of the State Auditor. I have attached a copy of the signature page for your convenience.

If you have any questions, please don't hesitate to contact me by email or at (651) 284-3423.

Sincerely,

Karen Morales
Pension Analyst
Office of the State Auditor

The Office of the State Auditor does not provide legal or investment advice. If you need legal or investment advice, consult with your attorney or investment advisor.

Caution: This e-mail may contain CONFIDENTIAL information or information protected by state or federal law. If you have received this e-mail by mistake, please do not read, distribute, or reproduce it (including any attachments). Please notify us immediately by return e-mail, and then delete it from your system. Thank you.

**Hamburg SC-17 Signature Page.pdf**

133K

To be eligible for fire state aid this Schedule Form must be fully completed, certified by the relief association officers, forwarded to the municipal clerk/independent secretary on or before August 1, 2017, and submitted to the Office of the State Auditor.

Relief Association Officer Certification

I have obtained a copy of the schedule form with Confirmation Id aa3e41fe-0d1b-450a-8bb8-d6878e41d383 displayed in the lower left corner of each page.

We, the officers of the Hamburg Fire Relief Association certify that this Schedule Form was prepared under Minn. Stat. § 424A.092 and that:

- 1) The annual benefit level of \$1,600 per year of service was established according to the average amount of available financing;
- 2) We understand that this form shows that the Relief Association has a projected DEFICIT of \$38,354 and a projected funding ratio of 92.21 percent;
- 3) The required 2018 contribution is \$14,119 based on the financial requirements of the Relief Association's Special Fund for the 2017 calendar year; (2018 Budget = \$10,355)
- 4) The Maximum Benefit Worksheet (MBW) portion of this form shows that the Relief Association's maximum allowable benefit level for 2017 is \$2,100;
- 5) We understand that the Relief Association cannot establish a benefit level that exceeds this statutory maximum. We understand that municipal or independent nonprofit firefighting corporation board approval may be required for a benefit increase; and
- 6) On or before August 1, the average amount of available financing per active member for the most recent three-year period was calculated on the MBW portion of this form in accordance with Minn. Stat. § 424A.02, subd. 3.

Signature of President	First Name	Last Name	Date
Signature of Secretary	First Name	Last Name	Date
Signature of Treasurer	First Name	Last Name	Date

Municipal Clerk / Independent Secretary Certification*

I received the completed Schedule Form from the Hamburg Fire Relief Association with Confirmation Id aa3e41fe-0d1b-450a-8bb8-d6878e41d383 displayed in the lower left corner of each page.

I have reviewed Line 15 of the Schedule Form. If Line 15 shows a required contribution, I certify that I will advise the governing municipal body or the independent nonprofit firefighting corporation of any required contribution at its next regularly scheduled meeting.

Signature of Municipal Clerk / Secretary of independent nonprofit firefighting corporation	First Name	Last Name	Date
--	------------	-----------	------

* See the form instructions for additional information about certification requirements.

Minnesota Pump Works
 1 Cannon Street W
 Dundas, MN 55019



Quote

Prepared By	Jenny Braith	Created Date	3/5/2018
Phone	877-645-8004	Quote Number	00001559
Email	info@minnesotapumpworks.com	Sales Rep	Chad Kubasch
		Expiration Date	3/15/2018
Bill To	Hamburg MN, City of PO Box 248 Hamburg, MN 55339	Ship To	Hamburg MN, City of 181 Broadway Ave Hamburg, MN 55339

Sale of ABS Pump to Replace Existing Obsolete Flygt Model 3126
 Note: Pricing does not include installation

Product Code	Product	Comment	Quantity	Rate	Total
GX6K3C4C1111321	ABS XFP100E CB1.4 PE90/4 12/230/3 49' XP 4" D/C		1.00	\$8,948.00	\$8,948.00
16907006	ABS SEAL LEAK/OVER TEMP RELAY, CA462, DIN RAIL MOUNTED, 110/230V-AC, INCLUDES BUILT IN MINICAS CONVERTER		1.00	\$362.00	\$362.00
	MISC PARTS	4" ADAPTER BRACKET W/GROMMET AND HARDWARE	1.00	\$506.64	\$506.64
	ON-SITE SERVICE LABOR - STD - N	ESTIMATED	2.00	\$110.00	\$220.00
	SERVICE DRIVE TIME - STD - N		2.50	\$110.00	\$275.00
	SERVICE TRUCK MILEAGE - STD - N		116.00	\$1.25	\$145.00
				Subtotal	\$10,456.64
				Total	\$10,456.64

XFP100E CB1 60HZ (wet pit)

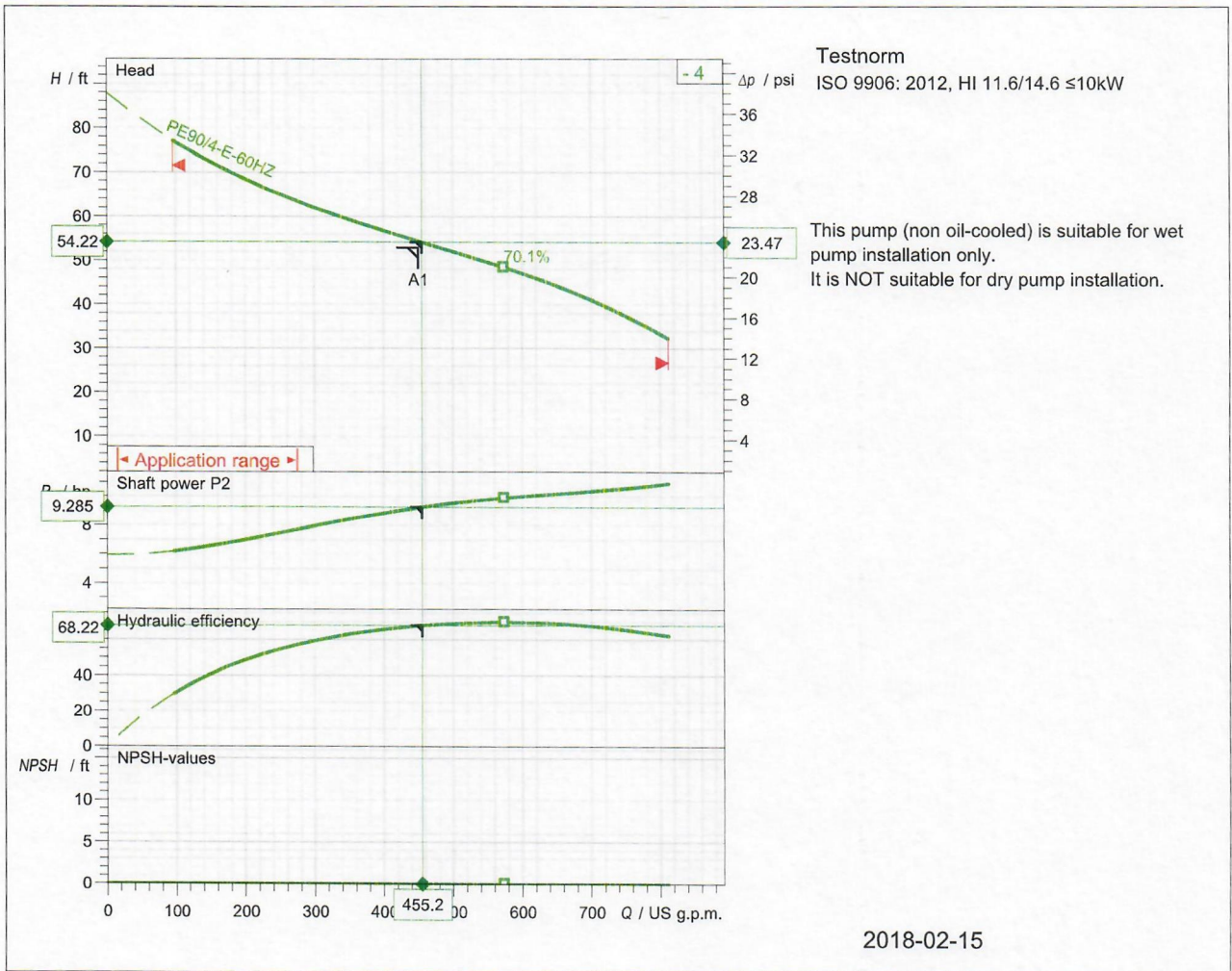

Operating data specification Flow 455 US g.p.m. Efficiency 68,2 % NPSH 0 ft Temperature 68 °F No. of pumps 1		Power input 10,1 hp Head 54,2 ft Shaft power 9,28 hp Fluid Wastewater Nature of system Single head pump	
Pump data Type XFP100E CB1 60HZ (wet pit) Series XFP PE1-PE3 N° of vanes 1 Free passage 3,15 inch Discharge flange DN100 Moment of inertia 0,574 lb ft²		Make SULZER Impeller Contrablock Plus impeller, 1 vane Impeller size 8,54 inch Suction flange DN100 Type of installation Wet Well installation with pedestal	
Motor data Rated voltage 230 V Rated power P2 12,1 hp Number of poles 4 Power factor 0,78 Starting current 211 A Starting torque 87,1 lbf ft Insulation class H		Frequency 60 Hz Nominal Speed 1760 rpm Efficiency 91,7 % Rated current 31,6 A Rated torque 36 lbf ft Degree of protection IP 68 No. starts per hour 15	

Sulzer reserves the right to change any data and dimensions without prior notice and can not be held responsible for the use of information contained in this software.

Curve number		Pump performance curves			SULZER	
Reference curve XFP100E CB1 60HZ						
				Discharge DN100	Frequency 60 Hz	
Density 62,31 lb/ft ³	Viscosity 1 mm ² /s	Testnorm ISO 9906: 2012, HI 11.6/14.6 ≤10kW		Rated speed 1772 rpm	Date 2018-02-15	
Flow 455 US g.p.m.	Head 54,2 ft	Shaft power 9,28 hp	Power input 10,1 hp	Hydraulic efficiency 68,2 %	NPSH 0 ft	

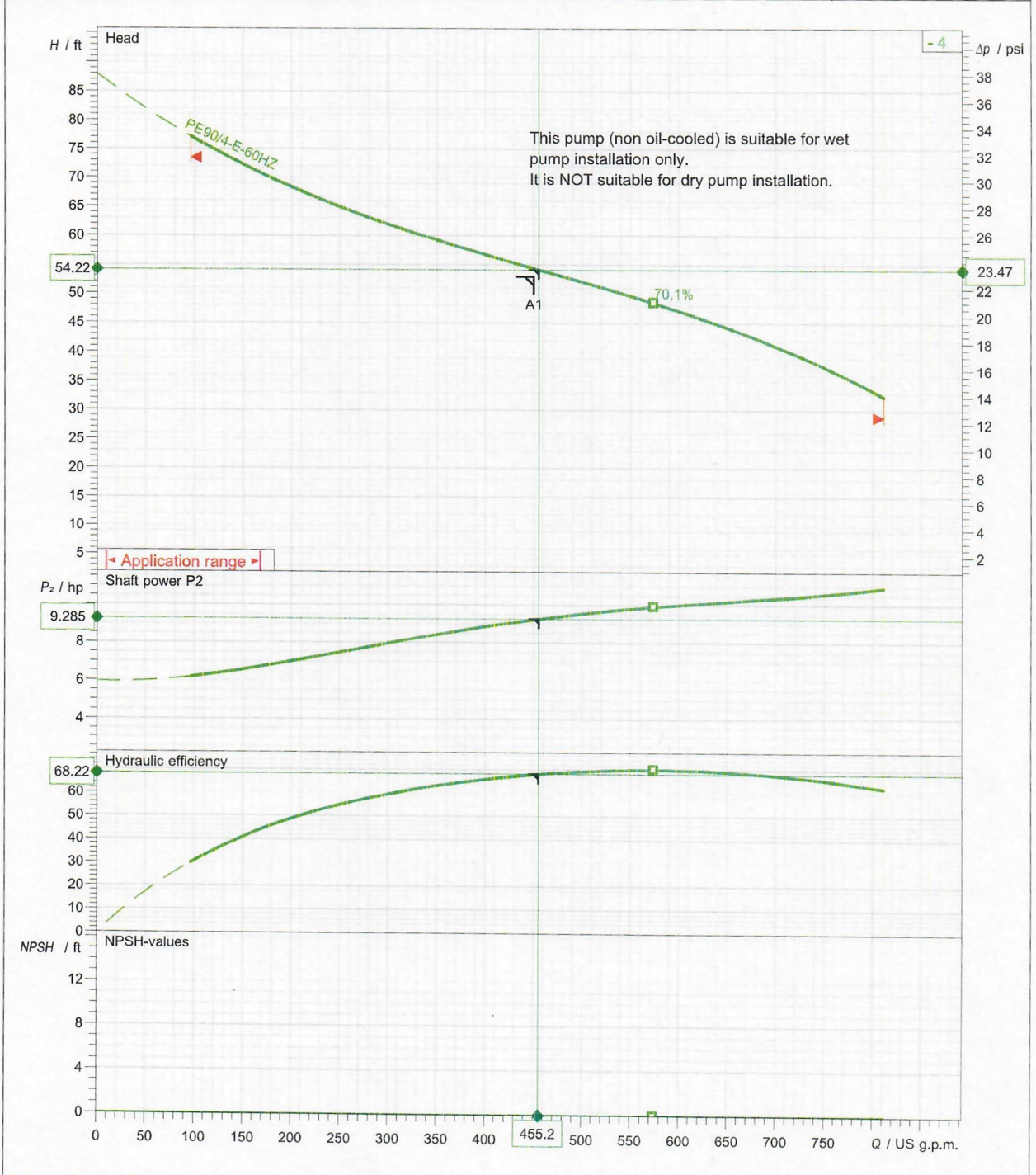

Impeller size 8,54 inch	N° of vanes 1	Impeller Contrablock Plus impeller, 1 vane	Solid size 3,15 inch	Revision
----------------------------	------------------	---	-------------------------	----------

Sulzer reserves the right to change any data and dimensions without prior notice and can not be held responsible for the use of information contained in this software.

Frequency
60 Hz

PE2

Motor performance curve



PE90/4-E-60HZ

Rated power
12,1 hp

Service factor
1,3

Nominal Speed
1760 rpm

Number of poles
4

Rated voltage
230 V

Date
2018-02-15

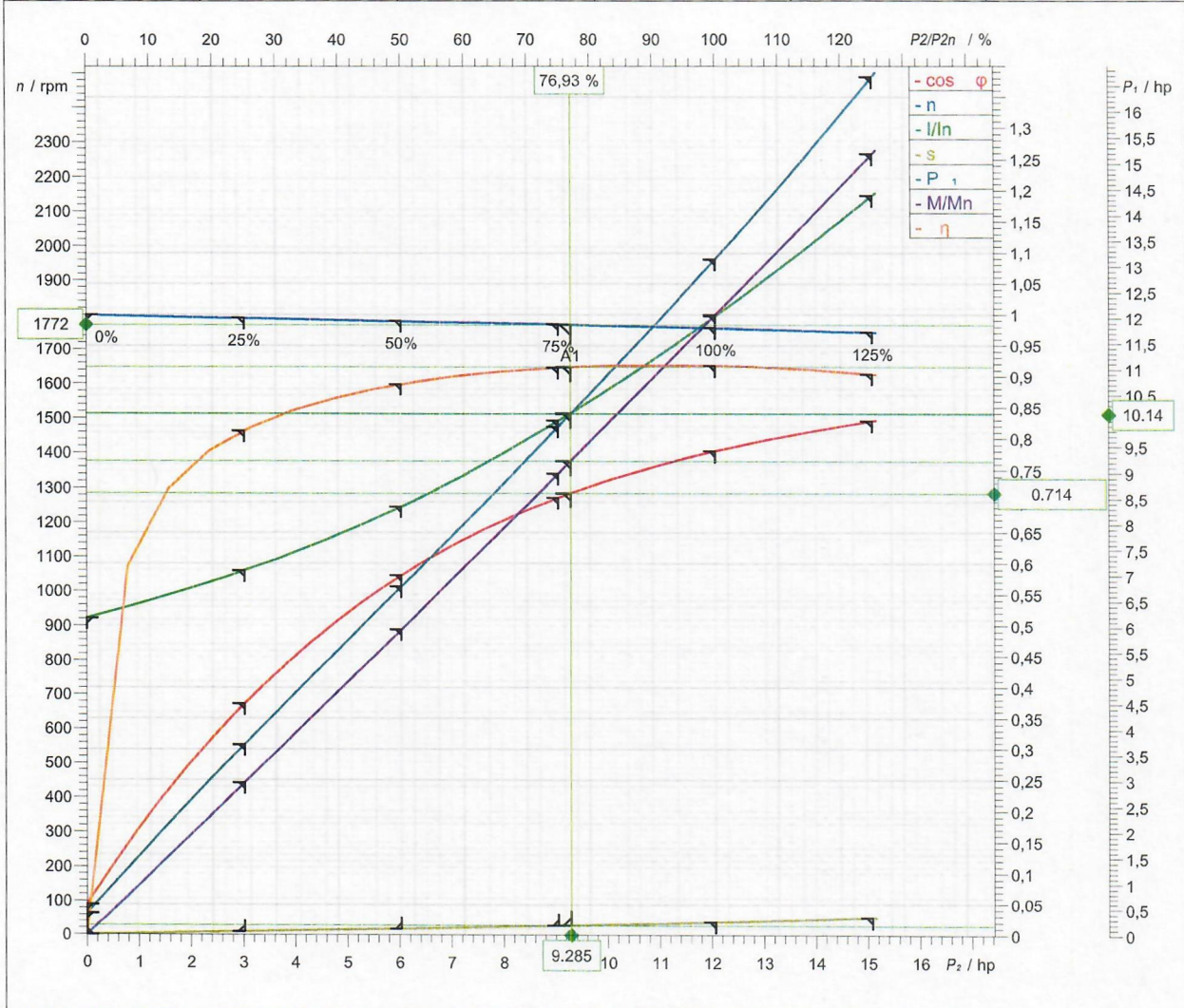

Symbol	No load	25 %	50 %	75 %	100 %	125 %
P ₂ / hp	0	3,017	6,035	9,052	12,07	15,09
P ₁ / hp	0,4334	3,712	6,794	9,895	13,15	16,68
η / %	0	81,28	88,82	91,48	91,76	90,44
n / rpm	1800	1791	1782	1773	1762	1749
cos φ	0,05011	0,3737	0,5812	0,7067	0,7806	0,8289
I / A	16,19	18,6	21,88	26,21	31,54	37,67
s / %	0	0,4975	0,9836	1,504	2,103	2,817
M / lbf ft	0	8,848	17,78	26,82	35,97	45,3

Tolerance according to VDE 0530 T1 12.84 for rated power

Starting current
211 A

Starting torque
87,1 lbf ft

Moment of inertia
1,07 lb ft²

No. starts per hour
15

QUOTATION

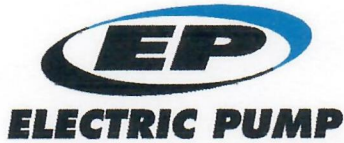

201 4th Ave SW
New Prague, MN 56071 USA

Telephone: (952)758-6600 / FAX (952)758-7778
Toll Free 1-800-536-5394

www.electricpump.com

QUOTE NUMBER: 0175569
QUOTE DATE: 2/28/2018
EXPIRE DATE: 3/28/2018

SALESPERSON: STEVE REED
CUSTOMER NO: 0013157
QUOTED BY: MKH
PARK LS FLYGT 3127

QUOTED TO:
CITY OF HAMBURG
PO BOX 248
HAMBURG, MN 55339-0248

JOB LOCATION:
CITY OF HAMBURG
181 BROADWAY
HAMBURG, MN 55339

CONFIRM TO:
GREG SCHULTZ 952-467-3803

*** QUOTE ORDER - DO NOT PAY ***

CUSTOMER P.O.	SHIP VIA	F.O.B.	TERMS			
	EP TRUCK		NET 30 DAYS			
ITEM NUMBER	UNIT	ORDERED	SHIPPED	BACK ORDER	PRICE	AMOUNT
RE: REPLACE FLYGT 3126 WITH 3127 HARD IRON IMPELLER PUMP AT PARK LIFT						
ELECTRIC PUMP OFFERS:						
0031270600039	EACH	1.00	0.00	0.00	10,185.00	10,185.00
FLYGT MODEL 3127 NP488-4" 10HP/230V/3 25 FLA, 1750 RPM 50' POWER CORD, FLS FV, INCLUDES GUIDE BRACKET FOR PUMP TO SLIDE DOWN THE EXISTING GUIDE RAIL SYSTEM. ---HARD IRON IMPELLER AND WEAR PLATE (25% HIGH CHROME CONTENT) ---FLS MOISTURE SENSOR IN STATOR WIRED IN SERIES WITH THE THERMALS ---INCLUDES FLYGT STANDARD 5 YEAR WARRANTY.						
1400000407129	EACH	1.00	0.00	0.00	512.00	512.00
FLYGT MINI-CAS RELAY TO BE INSTALLED IN THE EXISTING CONTROL PANEL.						
*ADAPTER	EACH	1.00	0.00	0.00	0.00	0.00
4" ADAPTER BRACKET AND GROMMET IS NOT NEEDED ON A FLYGT PUMP UNLESS THE BASE ELBOW IS WORN AND THERE IS BLOW BY. ***IF THERE IS BLOW BY AND THE BRACKET & GROMMET IS NEEDED FOR PUMP TO SEAT PROPERLY, ADDED COST = \$460.00						
*INSTALL	EACH	1.00	0.00	0.00	700.00	700.00
EP CONTROLS TECH TO INSTALL THE MINI CAS RELAY IN PANEL. EP SERVICE TECH TO INSTALL NEW FLYGT PUMP AND PERFORM START UP SERVICES. PUMP IS IN STOCK IN OUR DES MOINES SHOP.						

*** Continued ***

QUOTATION



201 4th Ave SW
New Prague, MN 56071 USA

Telephone: (952)758-6600 / FAX (952)758-7778
Toll Free 1-800-536-5394

www.electricpump.com

QUOTE NUMBER: 0175569
QUOTE DATE: 2/28/2018
EXPIRE DATE: 3/28/2018

SALESPERSON: STEVE REED
CUSTOMER NO: 0013157
QUOTED BY: MKH
PARK LS FLYGT 3127

QUOTED TO:
CITY OF HAMBURG
PO BOX 248
HAMBURG, MN 55339-0248

JOB LOCATION:
CITY OF HAMBURG
181 BROADWAY
HAMBURG, MN 55339

CONFIRM TO:
GREG SCHULTZ 952-467-3803

***** QUOTE ORDER - DO NOT PAY *****

CUSTOMER P.O.	SHIP VIA	F.O.B.	TERMS
	EP TRUCK		NET 30 DAYS

ITEM NUMBER	UNIT	ORDERED	SHIPPED	BACK ORDER	PRICE	AMOUNT
-------------	------	---------	---------	------------	-------	--------

PLEASE CONTACT US WITH ANY QUESTIONS OR TO PLACE AN ORDER.

THANK YOU FOR YOUR CONSIDERATION.
SINCERELY--MYRA HOFFMAN 800-211-6432
CC: STEVE REED 612-325-9980

All return goods must have written approval from Electric Pump, Inc. before returning. Credit will not be issued without written approval and if applicable there will be a Restock Fee.

Net Order:	11,397.00
Less Discount:	0.00
Freight:	0.00
Sales Tax:	0.00
Order Total:	11,397.00

ABOVE PRICING EFFECTIVE FOR 30 DAYS

MiniCAS

Features

- 120 VAC, 24 VAC, or 24 VDC Powered
- Durable Plastic Enclosure with Flange for Mounting
- Leakage & Temperature Alarm Indication
- Power Applied Indication
- Temperature Alarm Reset Mode Select Switch (Auto or Manual)
- Temperature Alarm Reset Push-button
- Sensor Input Transient & Short Circuit Protection

Operation

The MiniCAS provides Motor Over Temperature and Seal Leakage protection for Flygt Submersible Pumps equipped with FLS or CLS sensors. The unit supplies 12 VDC to the sensor and measures the current through the sensor using protected, noise-filtered electronic circuitry. When sensor current is in the normal range, the Temperature Alarm Relay is activated to allow normal pump operation.

High Temperature Condition

In a motor High Temperature condition, the pump thermal contacts open and the current becomes zero. The Overtemp Indication is turned on and the Temperature Alarm Relay is deactivated, preventing pump operation. When the motor High Temperature condition has cleared, the unit will reset based on the position of the Alarm Reset Mode Select Switch (Auto or Manual). In the Auto position, the Overtemp Alarm resets automatically. In the Manual position, the Overtemp Reset Push-button must be pushed to clear the alarm.

Seal Leakage Condition

In a Seal Leakage condition, the Flygt FLS or CLS sensor decreases its internal resistance. The increased current is sensed, the Leakage Indication is turned on, and the Leakage Alarm Relay is activated.

Shorted Sensor Condition

If the sensor wires are shorted, a Shorted Sensor condition is indicated by activating the Leakage Alarm Relay and alternately flashing both the Leakage and Overtemp LED together with the Power LED. If the short is removed, the fault will automatically reset within 30 seconds.

Cleared Fault Indication

For both Overtemp and Seal Leakage conditions, a cleared fault indication is provided. If either condition has occurred, but has been automatically cleared, then the corresponding indication will slowly flash. The flashing indication may be manually removed by pressing the Overtemp Reset Push-button.

Specifications

Input Power:	120 VAC ± 10% 3.5 VA max. 24 VAC ± 10% 3.5 VA max. 24 VDC ± 10% 125 mA max.
Output Rating:	NEMA B300 Pilot Duty, 1/6th HP, 3A @ 240 VAC Form C
Operating Temp:	-20°C to 60°C
Storage Temp:	-40°C to 80°C
Sensor Voltage:	12 VDC ± 10%
Temp. Alarm Trip Point:	<3.0 mA ± 5%
Leak Alarm Trip Point:	>22 mA ± 5%
Shorted Sensor Trip Point:	>64 mA ± 5%



UL FILE # 222351



MADE IN THE U.S.A.

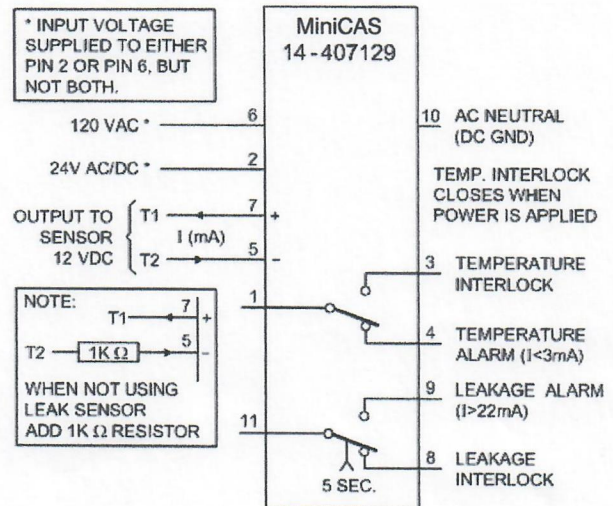
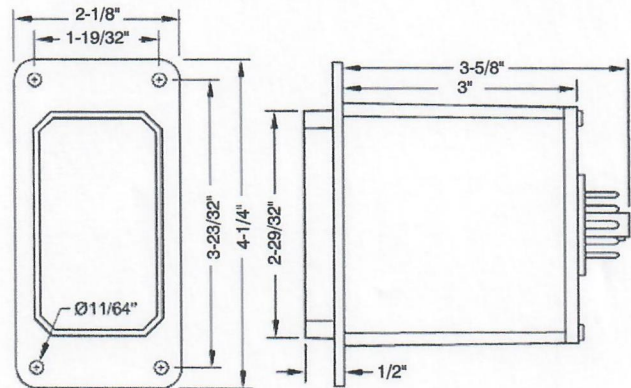

ORDERING INFORMATION

The Flygt Clog Free Guarantee

FLYGT PUMPS EQUIPPED WITH N-TECHNOLOGY ARE GUARANTEED TO BE CLOG FREE



Flygt guarantees that its solids-handling pumps, when equipped with impellers utilizing the self-cleaning N-technology, will be free from clogging for 12 months when pumping sewage and wastewater containing solids and debris normally found in domestic wastewater.

Flygt's patented N-technology, now with revolutionary Adaptive N-technology, ensures continuous, trouble free pumping while delivering sustained efficiency regardless of the wastewater challenges, handling stringy fibrous materials and modern trash.

Flygt brand solids-handling pumps equipped with N-technology are guaranteed to operate clog free for 12 months. It's our Clog Free Operations Guarantee.

Contact your authorized Flygt representative for details.



FLYGT

✓ Clog Free Guarantee

The guarantee is extended to the original owner of the pumps for a period of 12 months from the date of start-up of the equipment by the local authorized Flygt representative or distributor.

Should the Flygt N-Pump Impeller clog with typical solids and/or debris normally found in domestic wastewater during this period, an authorized representative will reimburse the owner for reasonable cost to remove the pump, clear the obstruction and reinstall the affected pump unit.

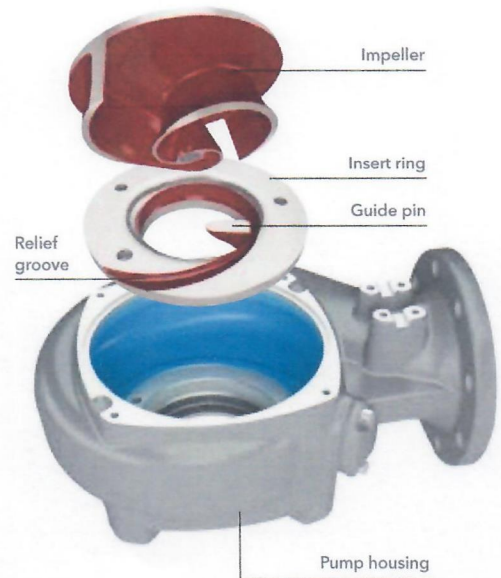

FB173 • Flygt Clog Free Guarantee Flyer • 11/2014 • US

✓ 25% Energy Savings Guarantee

Replace a competitor's non-clog, solids handling pump with a Flygt N-Pump and you will use a minimum of 25% less energy for pumping. We guarantee it.

This guarantee applies to all retrofit applications (lift stations and treatment plants) with solids-bearing liquids. If you do not see at least 25% in pump energy savings, we will refund the difference between the actual pump energy savings and the expected 25% savings for a 3-year period of operation.

The self-cleaning concept

All Flygt N-pumps have the same self-cleaning performance regardless of duty point.



A. Conventional wastewater pump

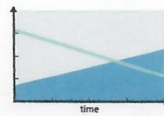

B. Conventional pump running intermittently

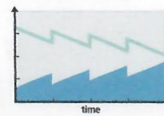

C. Flygt N-pump

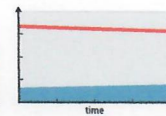

— Hydraulic efficiency
— Sustained high efficiency
— Energy consumption

✓ Flygt Hard Iron Advantage

Less erosion, less maintenance.

Hard-Iron (60HRC) is suitable for the toughest wastewater applications with abrasives. In accelerated wear tests, the lifetime of a Hard Iron impeller was more than three times longer than an impeller made of hardened cast iron. Choosing Hard Iron reduces time and money spent on maintenance.

Contact your local Flygt representative for details.

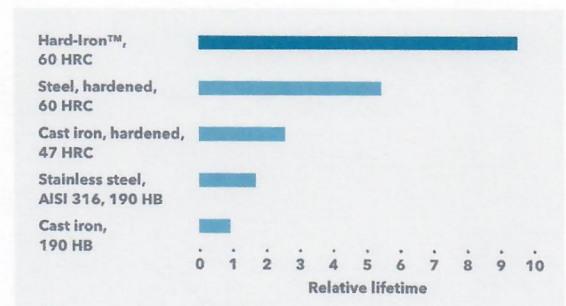

xylem
Let's Solve Water

Flygt is a brand of Xylem, whose 12,000 employees are addressing the most complex issues in the global water market.

www.xylem.com

Xylem, Inc.
14125 South Bridge Circle
Charlotte, NC 28273
Tel 704.409.9700
Fax 704.295.9080



Building a Better World
for All of Us®

March 13, 2018

RE: City of Hamburg, Minnesota
Comprehensive Plan Update
SEH No. P-HAMBU 145587 10.03

Jeremy Gruenhagen
City Clerk
City of Hamburg
PO Box 248
Hamburg, MN 55339

Dear Jeremy:

We are submitting this proposal to assist the City with a comprehensive plan update. The proposal outlines scope of work for updating three elements of the City's comprehensive plan: wastewater, water supply, and surface water/land use.

BACKGROUND

Carver County along with the cities located within the County are required to update their comprehensive plan every ten years. The comprehensive plans are to align with the Metropolitan Council's regional system plans.

The County and cities are required to complete this comprehensive plan update, and submit it to the Metropolitan Council for review and approval by the end of 2018.

Work should begin on this update now to provide enough time for review and approvals from the governing agencies.

WORK PLAN

SEH will work closely with the City of Hamburg to complete the wastewater, water supply, and surface water/land use portions of the Plan update.

SEH will start the project within two weeks of approval to proceed by requesting information and data needed for the Plan update. This information will then be compiled and used to complete the first draft of the Plan. Additional information required to provide clarity, questions regarding the Plan, or items of concern will be identified while completing the first draft of the Plan. These items, along with the draft, will be forwarded to the City for review.

After City staff reviews the draft, we will have a meeting to review the Plan together. Meeting minutes will be provided and include action items and identify any additional information required based upon review of the draft Plan and comments or modifications to be incorporated into the Plan.

The Plan will be updated based on the City's comments from the meeting and additional data received. Once updated, the Plan will be submitted to the City for a final review. A second meeting will be held to

Engineers | Architects | Planners | Scientists

Short Elliott Hendrickson Inc., 1390 Highway 15 South, Suite 200, P.O. Box 308, Hutchinson, MN 55350-0308

SEH is 100% employee-owned | sehinc.com | 320.587.7341 | 800.838.8666 | 888.908.8166 fax

review the final Plan and make final modifications. Upon completion and City approval, the Plan will be submitted to Carver County for review and approval. SEH will respond to questions that Carver County may have regarding the Plan as required to secure plan approval.

SCHEDULE

SEH will begin work within two weeks of approval to proceed. The update process is anticipated to require 2 to 3 months depending on the County review timeline.

FEE

The cost for updating the wastewater, water supply, and surface water/land use to meet the minimum requirements as outlined by Carver County is estimated as follows:

Water Supply	\$11,000
Wastewater	\$5,500
Surface Water/Land Use	\$15,500

The total cost for the updating the wastewater, water supply, and surface water/land use is estimated at \$32,000. Additional planning services or mapping above and beyond the minimum update requirements are not included in this proposal.

We look forward to working with the City of Hamburg on this update. Please sign two copies of the attached Supplemental Letter Agreement (SLA), keep one copy for your files, and return one copy to our office.

If you have any questions, please contact me at 952.913.0702.

Sincerely,

SHORT ELLIOTT HENDRICKSON INC.

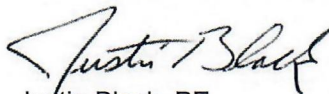

Justin Black, PE
Project Manager

jb
Enclosure

Supplemental Letter Agreement

In accordance with the Master Agreement for Professional Services between City of Hamburg, Minnesota ("Client"), and Short Elliott Hendrickson Inc. ("Consultant"), effective March 25, 2015, this Supplemental Letter Agreement dated March 13, 2018, authorizes and describes the scope, schedule, and payment conditions for Consultant's work on the Project described as: Comprehensive Plan Update.

Client's Authorized Representative: Jeremy Gruenhagen
Address: PO Box 248
Hamburg, MN 55339
Telephone: 952.467.3232 **email:** hamburgcityhall@gmail.com

Project Manager: Justin Black, PE
Address: PO Box 308
Hutchinson, MN 55350
Telephone: 952.913.0702 **email:** jblack@sehinc.com

Scope: The Basic Services to be provided by Consultant:

SEH will assist the City in updating three elements of the City's comprehensive plan: wastewater, water supply, and surface water/land use, as indicated in the attached proposal letter dated March 13, 2018.

Schedule: We will begin our services within two weeks of approval to proceed by receipt of a signed copy of this Supplemental Letter Agreement, and will complete our services in approximately 2 to 3 months, as indicated in the attached proposal letter dated March 13, 2018.

Payment: The estimated fee is hourly, subject to a not-to-exceed amount of \$32,000 including expenses and equipment. The estimated fee for each Task is as indicated in the attached proposal letter dated March 13, 2018, and as follows:

Water Supply	\$11,000
Wastewater	\$5,500
Surface Water/Land Use	\$15,500
Total Fee	\$32,000

The payment method, basis, frequency and other special conditions are set forth in attached Exhibit A-1.

Other Terms and Conditions: Other or additional terms contrary to the Master Agreement for Professional Services that apply solely to this project as specifically agreed to by signature of the Parties and set forth herein: None.

h:\f\lh\hambur\common\145587\suppl ltr agr_031318.docx

Short Elliott Hendrickson Inc.

City of Hamburg, Minnesota

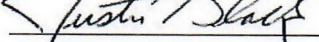
By: 
Justin Black, PE
Title: Client Service Manager

By: _____
Title: _____

Exhibit A-1
to Supplemental Letter Agreement
Between City of Hamburg, Minnesota (Client)
and
Short Elliott Hendrickson Inc. (Consultant)
Dated March 13, 2018

Payments to Consultant for Services and Expenses
Using the Hourly Basis Option

The Agreement for Professional Services is amended and supplemented to include the following agreement of the parties:

A. Hourly Basis Option

The Client and Consultant select the hourly basis for payment for services provided by Consultant. Consultant shall be compensated monthly. Monthly charges for services shall be based on Consultant's current billing rates for applicable employees plus charges for expenses and equipment.

Consultant will provide an estimate of the costs for services in this Agreement. It is agreed that after 90% of the estimated compensation has been earned and if it appears that completion of the services cannot be accomplished within the remaining 10% of the estimated compensation, Consultant will notify the Client and confer with representatives of the Client to determine the basis for completing the work.

Compensation to Consultant based on the rates is conditioned on completion of the work within the effective period of the rates. Should the time required to complete the work be extended beyond this period, the rates shall be appropriately adjusted.

B. Expenses

The following items involve expenditures made by Consultant employees or professional consultants on behalf of the Client. Their costs are not included in the hourly charges made for services and shall be paid for as described in this Agreement but instead are reimbursable expenses required in addition to hourly charges for services:

1. Transportation and travel expenses.
2. Long distance services, dedicated data and communication services, teleconferences, Project Web sites, and extranets.
3. Lodging and meal expense connected with the Project.
4. Fees paid, in the name of the Client, for securing approval of authorities having jurisdiction over the Project.
5. Plots, Reports, plan and specification reproduction expenses.
6. Postage, handling and delivery.
7. Expense of overtime work requiring higher than regular rates, if authorized in advance by the Client.
8. Renderings, models, mock-ups, professional photography, and presentation materials requested by the Client.
9. All taxes levied on professional services and on reimbursable expenses.
10. Other special expenses required in connection with the Project.
11. The cost of special consultants or technical services as required. The cost of subconsultant services shall include actual expenditure plus 10% markup for the cost of administration and insurance.

The Client shall pay Consultant monthly for expenses.

C. Equipment Utilization

The utilization of specialized equipment, including automation equipment, is recognized as benefiting the Client. The Client, therefore, agrees to pay the cost for the use of such specialized equipment on the project. Consultant invoices to the Client will contain detailed information regarding the use of specialized equipment on the project and charges will be based on the standard rates for the equipment published by Consultant.

The Client shall pay Consultant monthly for equipment utilization.

h:\fj\hambur\common\145587\exhibit a1.docx

Storm Sewer Pipe Usage Agreement

BETWEEN:

Steve, Tammy, and Jake Trebesch

Of 360 Sophia Ave
Telephone: (952)-412-8310
(the "landlord(s)")

OF THE FIRST PART

-AND-

City of Hamburg

Of 181 Broadway Ave
Telephone: (952)-467-3232
(the "Tenant")

OF THE SECOND PART

IN CONSIDERATION OF the Landlord(s) letting the city "rent" the storm sewer pipe to the Tenant, the Tenant renting the storm sewer pipe from the landlord and the mutual benefits and obligations set forth in this agreement, the receipt and sufficiency of which consideration is hereby acknowledged, the parties to this agreement The Trebesch's and the City of Hamburg agree as follows:

Definitions

1. When used in this agreement, the following expressions will have the meanings indicated:
 - a. "Additional Rent" means all amounts payable by the Tenant under this agreement except base rent, whether or not specifically designated as additional rent elsewhere in the agreement;
 - b. "Agreement area" the storm sewer pipe that runs across 419 Railroad St Hamburg MN 55339 and NYA township land ; 11.0282010, no land just the storm sewer pipe.

- c. "Pipe" means the storm sewer pipe that runs across 419 Railroad St Hamburg MN 55339 and NYA township land ; 11.0282010, which the Trebesch's own.
- d. "Rent" means the total of base rent, anything dropped off the water bill, and additional rent.

Intent of Agreement

2. It is the intent of this agreement to by the parties to this agreement that rent for this agreement will be on a gross rent basis meaning the tenant will pay the base rent and any additional rent and the landlord(s) will have their storm sewer usage bill relinquished and be paid the base rent and additional rent on an annual basis.

Agreement area

3. The landlord(s) agree to rent the tenant the storm sewer pipe (no land) located on properties 419 Railroad St Hamburg MN 55339 and NYA township land ; 11.0282010.

4. Although the tenant is "renting" the pipe, the tenant, anyone the tenant hires, anyone and or anything, they're not allowed to come on the land, work on the pipe, or dig up any land etc. until a written and/or verbal agreement has been made to be able to go on the land, go under ground, dig, etc. The tenant and/or whoever the tenant hires is also responsible for the repair of the land dug up to be able to work on the pipe, meaning must put sod down where dirt is shown, make the land flat again, and looks the way it was before digging was started.

5. Any work that has to be done to the pipe, the tenant is responsible for fixing the pipe. The tenant is responsible for the bill of repair on the pipe and the liability of any injuries or deaths that happen during the pipe is being fixed, in the case the pipe needs repair. Work can only be done once the landlord(s) has been notified and makes a written and/or verbal agreement for the tenant to agree to.

Term

6. This agreement is in effect of January 1st 2018 and ends never as long as the land is never split. In the case of someone else purchasing it, they get to take part in this agreement and get the same benefits, as long as the terms remain.

Rent / Additional rent

7. The tenant will pay the base rent of \$1,000.00, payable per year, at the beginning of the year.

8. The tenant will take the storm sewer usage part of the water bill for any properties, and/or properties that the landlord(s) own on the west side of the tracks. The tenant will also take off any bills made for anything storm sewer related on the west side of the tracks for whoever owns the properties 419 Railroad St Hamburg MN 55339 and NYA township land ; 11.0282010.

9. The tenant will pay additional rent if the rate of the storm sewer usage and/or any bills made and/or related to the storm sewer goes up on the water bills for the citizens of Hamburg. The tenant will also pay additional rent if property tax goes up.

Failure to Pay Rent

10. If the tenant fails to pay the rent, the storm sewer usage fee and/or any fee related to storm sewer on the water bills for citizens of Hamburg MN will still be taken off for all properties on the west side of the tracks in Hamburg MN for the owners of 419 Railroad St Hamburg MN 55339 and NYA township land ; 11.0282010.

11. Also in the case the tenant fails to pay rent, there will be a penalty fee of \$30.00 each month it's late.

12. If the tenant fails to pay after 1 year of the due date, the pipe will be terminated.

IN WITNESS WHEREOF the parties to this agreement have duly affixed their signatures under hand and seal, or by a duly authorized officer seal, on this _____ day of _____, 20____

(Witness)

Steve Trebesch (landlord)

(Witness)

Tammy Trebesch (landlord)

Jake Trebesch (landlord)

City of Hamburg (tenant)

13D.04 NOTICE OF MEETINGS.

§

Subdivision 1.Regular meetings.

A schedule of the regular meetings of a public body shall be kept on file at its primary offices. If a public body decides to hold a regular meeting at a time or place different from the time or place stated in its schedule of regular meetings, it shall give the same notice of the meeting that is provided in this section for a special meeting.

§

Subd. 2.Special meetings.

(a) For a special meeting, except an emergency meeting or a special meeting for which a notice requirement is otherwise expressly established by statute, the public body shall post written notice of the date, time, place, and purpose of the meeting on the principal bulletin board of the public body, or if the public body has no principal bulletin board, on the door of its usual meeting room.

(b) The notice shall also be mailed or otherwise delivered to each person who has filed a written request for notice of special meetings with the public body. This notice shall be posted and mailed or delivered at least three days before the date of the meeting.

(c) As an alternative to mailing or otherwise delivering notice to persons who have filed a written request for notice of special meetings, the public body may publish the notice once, at least three days before the meeting, in the official newspaper of the public body or, if there is none, in a qualified newspaper of general circulation within the area of the public body's authority.

(d) A person filing a request for notice of special meetings may limit the request to notification of meetings concerning particular subjects, in which case the public body is required to send notice to that person only concerning special meetings involving those subjects.

(e) A public body may establish an expiration date for requests for notices of special meetings pursuant to this subdivision and require refiling of the request once each year.

(f) Not more than 60 days before the expiration date of a request for notice, the public body shall send notice of the refiling requirement to each person who filed during the preceding year.

§

Subd. 3. Emergency meetings.

(a) For an emergency meeting, the public body shall make good faith efforts to provide notice of the meeting to each news medium that has filed a written request for notice if the request includes the news medium's telephone number.

(b) Notice of the emergency meeting shall be given by telephone or by any other method used to notify the members of the public body.

(c) Notice shall be provided to each news medium which has filed a written request for notice as soon as reasonably practicable after notice has been given to the members.

(d) Notice shall include the subject of the meeting. Posted or published notice of an emergency meeting is not required.

(e) An "emergency" meeting is a special meeting called because of circumstances that, in the judgment of the public body, require immediate consideration by the public body.

(f) If matters not directly related to the emergency are discussed or acted upon at an emergency meeting, the minutes of the meeting shall include a specific description of the matters.

(g) The notice requirement of this subdivision supersedes any other statutory notice requirement for a special meeting that is an emergency meeting.

§

Subd. 4. Recessed or continued meetings.

(a) If a meeting is a recessed or continued session of a previous meeting, and the time and place of the meeting was established during the previous meeting and recorded in the minutes of that meeting, then no further published or mailed notice is necessary.

(b) For purposes of this subdivision, the term "meeting" includes a public hearing conducted pursuant to chapter 429 or any other law or charter provision requiring a public hearing by a public body.

§

Subd. 5. Closed meetings.

The notice requirements of this section apply to closed meetings.

§

Subd. 6. State agencies.

For a meeting of an agency, board, commission, or department of the state required or permitted by law to transact public business in a meeting:

(1) the notice requirements of this section apply only if a statute governing meetings of the agency, board, or commission does not contain specific reference to the method of providing notice;

(2) all provisions of this section relating to publication are satisfied by publication in the State Register or posting on the Web site of the agency, board, commission, or department; and

(3) a schedule of the regular meetings shall be kept on file at the primary offices or posted on the Web site of the agency, board, commission, or department.

§

Subd. 7. Actual notice.

If a person receives actual notice of a meeting of a public body at least 24 hours before the meeting, all notice requirements of this section are satisfied with respect to that person, regardless of the method of receipt of notice.

History:

1957 c 773 s 1; 1967 c 462 s 1; 1973 c 123 art 5 s 7; 1973 c 654 s 15; 1973 c 680 s 1,3; 1975 c 271 s 6; 1981 c 174 s 1; 1983 c 137 s 1; 1983 c 274 s 18; 1984 c 462 s 27; 1987 c 313 s 1; 1990 c 550 s 2,3; 1991 c 292 art 8 s 12; 1991 c 319 s 22; 1994 c 618 art 1 s 39; 1997 c 154 s 2; 2014 c 274 s 1

13D.05 MEETINGS HAVING DATA CLASSIFIED AS NOT PUBLIC.

§

Subdivision 1. General principles.

(a) Except as provided in this chapter, meetings may not be closed to discuss data that are not public data.

(b) Data that are not public data may be discussed at a meeting subject to this chapter without liability or penalty, if the disclosure relates to a matter within the scope of the public body's authority and is reasonably necessary to conduct the business or agenda item before the public body.

(c) Data discussed at an open meeting retain the data's original classification; however, a record of the meeting, regardless of form, shall be public.

(d) All closed meetings, except those closed as permitted by the attorney-client privilege, must be electronically recorded at the expense of the public body. Unless otherwise provided by law, the recordings must be preserved for at least three years after the date of the meeting.

§

Subd. 2. When meeting must be closed.

(a) Any portion of a meeting must be closed if expressly required by other law or if the following types of data are discussed:

(1) data that would identify alleged victims or reporters of criminal sexual conduct, domestic abuse, or maltreatment of minors or vulnerable adults;

(2) active investigative data as defined in section 13.82, subdivision 7, or internal affairs data relating to allegations of law enforcement personnel misconduct collected or created by a state agency, statewide system, or political subdivision;

(3) educational data, health data, medical data, welfare data, or mental health data that are not public data under section 13.32, 13.3805, subdivision 1, 13.384, or 13.46, subdivision 2 or 7; or

(4) an individual's medical records governed by sections 144.291 to 144.298.

(b) A public body shall close one or more meetings for preliminary consideration of allegations or charges against an individual subject to its authority. If the members

conclude that discipline of any nature may be warranted as a result of those specific charges or allegations, further meetings or hearings relating to those specific charges or allegations held after that conclusion is reached must be open. A meeting must also be open at the request of the individual who is the subject of the meeting.

§

Subd. 3. What meetings may be closed.

(a) A public body may close a meeting to evaluate the performance of an individual who is subject to its authority. The public body shall identify the individual to be evaluated prior to closing a meeting. At its next open meeting, the public body shall summarize its conclusions regarding the evaluation. A meeting must be open at the request of the individual who is the subject of the meeting.

(b) Meetings may be closed if the closure is expressly authorized by statute or permitted by the attorney-client privilege.

(c) A public body may close a meeting:

(1) to determine the asking price for real or personal property to be sold by the government entity;

(2) to review confidential or protected nonpublic appraisal data under section 13.44, subdivision 3; and

(3) to develop or consider offers or counteroffers for the purchase or sale of real or personal property.

Before holding a closed meeting under this paragraph, the public body must identify on the record the particular real or personal property that is the subject of the closed meeting. The proceedings of a meeting closed under this paragraph must be tape recorded at the expense of the public body. The recording must be preserved for eight years after the date of the meeting and made available to the public after all real or personal property discussed at the meeting has been purchased or sold or the governing body has abandoned the purchase or sale. The real or personal property that is the subject of the closed meeting must be specifically identified on the tape. A list of members and all other persons present at the closed meeting must be made available to the public after the closed meeting. If an action is brought claiming that public business other than discussions allowed under this paragraph was transacted at a closed meeting held under this paragraph during the time when the tape is not available to the public, section 13D.03, subdivision 3, applies.

An agreement reached that is based on an offer considered at a closed meeting is contingent on approval of the public body at an open meeting. The actual purchase or sale must be approved at an open meeting after the notice period required by statute or the governing body's internal procedures, and the purchase price or sale price is public data.

(d) Meetings may be closed to receive security briefings and reports, to discuss issues related to security systems, to discuss emergency response procedures and to discuss security deficiencies in or recommendations regarding public services, infrastructure and facilities, if disclosure of the information discussed would pose a danger to public safety or compromise security procedures or responses. Financial issues related to security matters must be discussed and all related financial decisions must be made at an open meeting. Before closing a meeting under this paragraph, the public body, in describing the subject to be discussed, must refer to the facilities, systems, procedures, services, or infrastructures to be considered during the closed meeting. A closed meeting must be tape recorded at the expense of the governing body, and the recording must be preserved for at least four years.

History:

1957 c 773 s 1; 1967 c 462 s 1; 1973 c 123 art 5 s 7; 1973 c 654 s 15; 1973 c 680 s 1,3; 1975 c 271 s 6; 1981 c 174 s 1; 1983 c 137 s 1; 1983 c 274 s 18; 1984 c 462 s 27; 1987 c 313 s 1; 1990 c 550 s 2,3; 1991 c 292 art 8 s 12; 1991 c 319 s 22; 1994 c 618 art 1 s 39; 1997 c 154 s 2; 1999 c 227 s 22; 2002 c 379 art 1 s 5; 2004 c 276 s 1; 2004 c 290 s 18; 2007 c 110 s 2; 2007 c 147 art 10 s 15; 2008 c 335 s 1; 2010 c 365 art 1 s 8