



HAMBURG CITY COUNCIL AGENDA

MARCH 22, 2022

1. **Call City Council Meeting to Order**
 - **Pledge of Allegiance**

2. **Public Comment** *(Individuals may address the City Council about any non-agenda item(s) of concern. Speakers must state their name, address, and limit their remarks to three minutes. The City Council may not take official action on these items and may refer the matter to staff for a future report or direct that the matter be scheduled for a future meeting agenda.)*

3. **Agenda Review (Added Items) and Adoption**

4. **Consent Agenda** *(NOTICE TO PUBLIC: All those items listed as part of the Consent Agenda will be approved by a single motion, unless a request to discuss one of those items is made prior to that time. Anyone present at the meeting may request an item to be removed from the consent agenda. Please inform the Council when they approve the agenda for this meeting.)*
 - **Approve Minutes for January 25, 2022 & March 8, 2022**
 - **Approve Payment of Added March 2022 Claims (\$103,170.70)**
 - **Approve Cash Flow Statement for February 2022**
 - **Approve Time-Off Request for Greg Schultz**
 - **Approve Highway 212 Letter of Support (Federal Financial Assistance)**
 - **Severe Weather Awareness Week April 4-8, 2022**
 - **Carver County Public Hearing (Variance for Emanuel Lutheran Church)**

5. **Old City Business**
 - **General Maintenance Worker**
 - **Personnel Committee Recommendation**
 - **2022 Street Improvement Project (Maria Ave/Louisa St)**
 - **Approve Resolution 2022-06 (Approving Plans/Specs & Advertisement for Bids for 2022 Street Improvements)**
 - **Tax Forfeited Parcel 45.0750061**
 - **Trebesch Litigation (Pre-Trial March 23rd @ 10:30 AM)**

6. **New City Business**

7. **City Council Reports**
 - **Councilmember Jason Buckentin (Streets)**
 - **Councilmember Eric Poppler (Parks)**
 - **Councilmember Jessica Weber (Buildings)**
 - **Councilmember Tim Tracy (Water/Sewer)**
 - **Mayor Chris Lund**

8. **Adjourn City Council Meeting**



***HAMBURG CITY COUNCIL AGENDA
MARCH 22, 2022***

COMMUNITY HALL & PARK ACTIVITIES

MARCH 9 – Hall Rental

**APRIL 23 – HFDRA Banquet
30 – Park Rental**

COMMUNITY CENTER (FIRE HALL) ACTIVITIES

MARCH

- 1 – Mayors In
- 6 – 4-H Meeting – 6:00 PM
- 7 – Hamburg Lions Board Meeting
- 7 – HFD Training
- 8 – Hamburg City Council Meeting
- 8 – Young America Annual Township Meeting
- 9 – Young America Township Board Meeting
- 14 – Young America Mutual
- 14 – Hamburg Fire Department
- 15-16 – Wm. Mueller & Sons Safety Meetings
- 21 – Hamburg Lions Club
- 22 – Hamburg City Council Meeting
- 28 – Hamburg Fire Dept. (Relief Association) Meeting

APRIL

- 3 – 4-H Meeting
- 4 – Hamburg Lions Board Meeting
- 4 – HFD Training
- 5 – Mayors In
- 10 – HFDRA Pork Chop Dinner
- 11 – Hamburg Fire Department
- 12 – Hamburg City Council Meeting
- 12 – Young America Township Meeting
- 18 – Hamburg Lions Club
- 25 – Hamburg Fire Dept. (Relief Association) Meeting

CITY OF HAMBURG
NOTICE OF A HAMBURG CITY COUNCIL MEETING
TUESDAY, MARCH 22, 2022
7:00 P.M.

NOTICE IS HEREBY GIVEN, that the City of Hamburg City Council will hold a City Council Meeting on Tuesday, March 22 2022 at 7:00 p.m., in the Council Chambers, 181 Broadway Avenue, Hamburg, MN.

This meeting is a regular scheduled meeting of the Hamburg City Council. This meeting will be held in the City Council Chambers and will be open to the public.

Members of the public can listen to and/or participate in the council meeting live online at <https://us02web.zoom.us/j/6817521480>, the Zoom App on your cellphone via the google play store, or by calling 1-312-626-6799. Use Meeting ID: 681 752 1480 when logging in or calling in. Use # as your participant ID.

To view a copy of the Agenda Packet please refer to the City Website: www.hamburgmn.com by clicking on the City Council Meetings tab. To be added to the Agenda please call City Offices by Noon on Monday.

If you have any questions, please contact City Hall (952) 467-3232 for further information.

POSTED BY THE HAMBURG CITY CLERK
Jeremy Gruenhagen, City Clerk/Treasurer



***HAMBURG CITY COUNCIL SPECIAL MEETING
JANUARY 25, 2022***

Mayor Chris Lund called the Hamburg Special Meeting to order at 6:30 p.m. Those in attendance were Councilmembers Eric Poppler, Jessica Weber, Tim Tracy, Jason Buckentin, and City Clerk Jeremy Gruenhagen.

Liquor License Applications Hamburg Lions

- February 5 - Fish Fry
- February 26 - Purse / Gun Bingo

MOTION: Councilmember Eric Poppler motioned to approve both of the Hamburg Lions Liquor License requests for February 5th and 26th. Seconded by Councilmember Jessica Weber. Motion was approved with all Councilmembers present.

MOTION: Councilmember Eric Poppler moved to adjourn the Special Meeting at 6:31 p.m. Seconded by Councilmember Jessica Weber. Motion was approved with all Councilmembers present.

Submitted on March 21, 2022
by Deputy Clerk Tamara Bracht

Amended/Approved on March 22, 2022



Jeremy Gruenhagen
City Clerk/Treasurer



HAMBURG CITY COUNCIL MEETING
MARCH 8, 2022

Acting Mayor Tim Tracy called the Hamburg City Council Meeting to order at 7:00 p.m. Those in attendance were Councilmember Eric Poppler, and Councilmember Jason Buckentin, City Clerk Jeremy Gruenhagen, Deputy Clerk Tamara Bracht. Duck House Donation Eli Pieper with Jeremy Vanderlinde, K.C. Koch, Mike Kaufman, Bill & Colleen Pieper. Resident David Chadwick. Absent were Councilmember Jessica Weber and Mayor Chris Lund.

Public Comment

No Public Comment.

Agenda Review (Added Items) and Adoption

MOTION: Councilmember Eric Poppler moved to approve the agenda as written. Seconded by Councilmember Jason Buckentin. Motion was approved by all in attendance.

Consent Agenda

- Approve Date Change for Public Hearing (City Zoning Map)
 - Move from March 8, 2022 to April 12, 2022 @ 7:00 PM
- Approve Minutes for February 8, 2022
- Approve Resolution Number 2022-05 (Reestablish Polling Place)
- Approve Payment of Added January 2022 Claims (\$31.87)
- Approve Payment of Added February 2022 Claims (\$22,448.84)
- Approve Payment of March 2022 Claims (\$32,997.94)
- Approve Temporary On-Sale Liquor License for Hamburg Lions
 - April 8, 2022 (Spring Bingo)
- Approve Cash Flow Statement for January 2022
- Approve Time-Off Request for Greg Schultz
- Approve Time-Off Request for Jeremy Gruenhagen
- Delinquent Utility Bills Report
- Severe Weather Awareness Week April 4-8, 2022
- Mediacom Rate Increase (Local Broadcast Station Surcharge)

MOTION: Councilmember Jason Buckentin moved to approve the Consent Agenda. Seconded by Councilmember Eric Poppler. Motion was approved by all in attendance.

Eli Pieper

- Duck Pond Memorial – Eli would like to build and donate a new duck house in honor of his two sons Logan and Ozzie. Council had no objections and welcomed the idea.
- Job Application Inquiry for Public Works Maintenance Worker.



HAMBURG CITY COUNCIL MEETING
MARCH 8, 2022

Mike Malz

- Big Rib Jig Festival (September 24, 2022)
 - Mr. Malz was not present.

John Egan

- Duck Pond (City Donation)
 - Mr. Egan was not present.
 - **MOTION: Councilmember Eric Poppler moved to approve a city donation of up-to \$250 toward ducks and feed. Seconded by Councilmember Jason Buckentin. Motion was approved by all present.**

Old City Business

- General Maintenance Worker
 - Personnel Committee Recommendation
 - **MOTION: Councilmember Eric Poppler moved to send a contingent offer of employment to Jason Kamrath. Seconded by Councilmember Jason Buckentin. Motion was approved by all present.**
- New Utility Billing Program
 - Transitioning and training have been going very well. We will go live on April 2nd.
- 2022 Street Improvement Project (Maria Ave/Louisa St)
 - Call for a Second Council Meeting for March (March 22, 2022) to approve Plans and Specifications and Advertisement for Bids.
 - **MOTION: Councilmember Jason Buckentin moved to hold a second council meeting on March 22 at 7:00 p.m. Seconded by Councilmember Eric Poppler. Motion was approved by all present.**
- Stabilization Ponds Riprap Project
 - First Phase of Improvements has been completed.
- City Zoning Map (Update)
 - Public Hearing on April 8th
- Trebesch Litigation
 - A Summary Judgement was made that Hamburg owns Track 5. Easements still need to be obtained for the portion of Storm Water on Tracts 3 & 4.
 - Pre-Trial March 23rd @ 10:30 AM

New City Business

- Tax Forfeited Parcel 45.0750061
 - Tabled item till the April 12th council meeting



***HAMBURG CITY COUNCIL MEETING
MARCH 8, 2022***

City Council Reports

- Councilmember Jason Buckentin (Streets) - nothing to report
- Councilmember Eric Poppler (Parks) - nothing to report
- Acting Mayor Tim Tracy - nothing to report

MOTION: Councilmember Jason Buckentin moved to adjourn the Hamburg City Council Meeting at 7:45 p.m. Seconded by Councilmember Eric Poppler. Motion was approved by all present.

Submitted on March 21, 2022
by Deputy Clerk Tamara Bracht

Amended/Approved on March 22, 2022



Jeremy Gruenhagen
City Clerk/Treasurer

2022 March Claims List

CHECK #	VENDOR	FUND	CLAIM DESCRIPTION	AMOUNT	APPROVED
ACH	EFTPS	Divided	Fed, Social Security, MC - February 2022	\$3,236.98	3/8/2022
ACH	MN Dept of Revenue	Divided	State Withholding Tax Payment - February 2022	\$568.00	3/8/2022
ACH	PERA	Divided	PERA Withholding - February 2022	\$556.99	3/8/2022
ACH	PERA	Divided	PERA Withholding - February 2022	\$825.25	3/8/2022
ACH	PERA	Divided	PERA Withholding - March 2022	\$616.69	3/22/2022
ACH	HealthPartners	Divided	Health Insurance for March 2022	\$4,845.96	3/8/2022
ACH	Google	General Gov't	Email Accounts (9) Administered by Google G Suite	\$168.00	3/8/2022
ACH	ZOOM	General Gov't	Video Conferencing Service	\$16.09	3/8/2022
ACH	Security Bank & Trust	General Gov't	ACH Service Fees for February 2021	\$30.60	3/8/2022
ACH	Optum Bank	General Gov't	City HSA Contribution for 1st Qtr 2022 (Jeremy & Greg)	\$1,250.00	3/8/2022
ACH	Verizon Wireless	Gen Gov't/PS (FD)	City Cell Phone/iPads for HFD	\$129.06	3/8/2022
ACH	Optum Bank	General Gov't	HSA Admin Fees for 1st Qtr 2022	\$7.50	3/22/2022
ACH	Jeremy Gruenhagen	Divided	March Wages (Rounds)	\$2,152.75	3/22/2022
ACH	Greg Schultz	Divided	Wages 2/21/22 to 3/6/22	\$2,242.08	3/22/2022
ACH	Tamara Bracht	Divided	Wages 2/21/22 to 3/6/22	\$1,015.57	3/22/2022
Debit Card	IDRIVE.Com	General Gov't	Computer Data Backup Program	\$99.50	3/8/2022
Debit Card	Hamburg Post Office	General Gov't	6 Rolls of Postcard Stamps, 1 Roll of Forever Stamps	\$298.00	3/8/2022
Debit Card	USPS	General Gov't	PO Box Rent Renewal	\$102.00	3/8/2022
Debit Card	Northern Tool & Equipment Co.	Hall	4 Floor Mats for Hall Cooler	\$150.49	3/22/2022
21013	Abdo	General Gov't	Certified Audit Services for Year Ended 12-31-2021	\$13,325.00	3/8/2022
21014	VOIDED	VOIDED	VOIDED PRINTING ERROR	\$0.00	3/8/2022
21015	Core & Main	Divided	Annual Support Contract 4-12-22 to 4-11-23	\$2,500.00	3/8/2022
21016	ECM Publishing	Hall	Bridal Guide Hall Advertisement	\$180.00	3/8/2022
21017	Herald Journal Publishing	General Gov't	Public Works Position Advertisement	\$218.00	3/8/2022
21018	McCleod Printing	General Gov't	Advertisement for Public Works Position	\$90.23	3/8/2022
21019	MN Dept. of Health	Water	1st Qtr. 2022 Community Water Supply Service Connection	\$524.00	3/8/2022
21020	Robb's Electric	Public Safety (FD)	Wirefor Gear Washer and Dryer in FD per quote	\$1,925.00	3/8/2022
21021	US Postal Service	General Gov't	Annual Renewal for PO Box Rent	\$102.00	3/8/2022
21022	Viking Bottling Co.	Hall	6 Syrup Tanks for Fountain Pop at Hall	\$192.00	3/8/2022
21023	W.W.O.T.A.	Divided	Water/Wastewater Training & Assistance for February 2022	\$405.00	3/8/2022
21024	Wm. Mueller & Sons	Divided	Truck & Sander on 2-25-22 & 3-6-22, Fuel for Equipment	\$1,237.78	3/8/2022
21025	VOIDED	VOIDED	VOIDED PRINTING ERROR	\$0.00	3/8/2022
21026	Branson Mecredy	Public Safety (FD)	RE-ISSUED (Wrong Name) - Chainsaw Repairs and Hydraulic Pump	\$172.50	3/8/2022
21027	Bolton & Menk, Ic.	General Gov't	Professional Services for Zoning Notices Jan. 8 - Feb. 4, 2022	\$160.00	3/22/2022
21028	Canon Financial	General Gov't	Canon Copier Gov't Contract - March	\$33.13	3/22/2022
21029	CarverLink	Divided	Internet Services - March	\$80.00	3/22/2022
21030	Cintas	Hall	Cleaning Supplies	\$86.51	3/22/2022
21031	City of Shakopee	Public Safety	SW Metro Drug Task Force Membership Dues for 2022	\$2,100.00	3/22/2022
21032	Coordinated Business Systems	General Gov't	Contract Base Rate for February 2022	\$57.69	3/22/2022
21033	Diversified Technology	Divided	1 Box of 5000 Perforated Water Bill Forms	\$237.97	3/22/2022
21034	Home Solutions	Hall	Paint Tray for Hall Cooler	\$4.31	3/22/2022
21035	Loffler Companies	General Gov't	February Copies	\$73.08	3/22/2022
21036	Melchert-Hubert & Sjodin, PLLP	General Gov't	Legal Fee's for Data Practices Act, 2022 Employee Handbook, Storm Sew	\$2,464.80	3/22/2022
21037	Menards	Divided	Dawn Dish Soap, AA & AAA Batteries, Toilet Valve Repair Kit, Water Soft	\$113.71	3/22/2022
21038	METRONET	Divided	Phone Service - March	\$66.75	3/22/2022
21039	MVTL Labs	Sewer	Sewer Pond Lab Work - Sample Dates 3-10-22 & 3-21-22	\$152.50	3/22/2022
21040	Northern Tool & Equipment Co.	Hall	4 Floor Mats for Hall Cooler	\$150.49	3/22/2022
21041	Plunkett's Pest Control	General Gov't Bldgs	General Pest Control - Office and Fire Dept. Serviced on 3-8-2022	\$39.37	3/22/2022
21042	Robb's Electric	Public Safety (FD)	Parts, Labor, & Bucket Truck for Repairs on Outside FD Building Lights	\$847.87	3/22/2022
21043	S.E.H. Inc.	Sewer	WWTP Rip Rap Project	\$1,241.00	3/22/2022
21044	Wm. Mueller & Sons	Sewer	WWTP Rip Rap Project	\$85,988.46	3/22/2022
21045	Xcel Energy	Divided	Electricity/Natural Gas Services	\$3,087.98	3/22/2022
				\$136,168.64	
			March Claims	\$32,997.94	
			Added March Claims	\$103,170.70	
				\$136,168.64	

	Beginning Balance 1/1/2022	2022 Budget Income	2022 Budget Expense	Budget Year-End Balance	Total Income Received	Total Expenses	Ending Balance 2/28/2022
General Fund	\$464,609.95	\$602,807.00	\$625,653.00	\$441,763.95	\$20,678.07	\$71,457.54	\$413,830.48
General Gov't							
Public Safety (Fire Dept.)			\$340,260.00			\$37,980.94	
Public Works (Streets)			\$123,458.00			\$6,637.34	
Sanitation & Recycling			\$55,923.00			\$20,272.18	
Parks & Recreation			\$4,500.00			\$0.00	
Comm. Hall			\$43,202.00			\$517.63	
			\$58,310.00			\$6,049.45	
Special Revenue Funds	\$563,619.35	\$20,340.00	\$29,520.00	\$554,439.35	\$0.00	\$0.00	\$563,619.35
City Of Hamburg (Savings)	\$549,310.70	\$14,285.00	\$29,520.00	\$534,075.70	\$0.00	\$0.00	\$549,310.70
*Equipment Replacement Fund	\$83,500.00	\$5,000.00	\$0.00	\$88,500.00			\$83,500.00
*City Maintenance Fund	\$108,000.00	\$5,000.00	\$0.00	\$113,000.00			\$108,000.00
*Street Improvements (Repairs)	\$272,782.00	\$0.00	\$0.00	\$272,782.00			\$272,782.00
*Community Center Addition	\$26,000.00	\$2,000.00	\$0.00	\$28,000.00			\$26,000.00
*Community Hall Renovations	\$0.00	\$0.00	\$0.00	\$0.00			\$0.00
*Park Handicap Bathrooms	\$18,000.00	\$2,000.00	\$0.00	\$20,000.00			\$18,000.00
*Water Tower	\$29,520.00	\$0.00	\$29,520.00	\$0.00			\$29,520.00
*Interest	\$11,508.70	\$285.00	\$0.00	\$11,793.70			\$11,508.70
*Transfers In (Out)	\$0.00	\$0.00	\$0.00	\$0.00			\$0.00
Fire Equipment CD	\$14,308.65	\$6,055.00	\$0.00	\$20,363.65	\$0.00	\$0.00	\$14,308.65
Debt Service	\$20,343.77	\$30,927.00	\$42,112.25	\$9,158.52	\$0.00	\$16,242.50	\$4,101.27
Total (Tax Revenue Funds)	\$1,048,573.07	\$654,074.00	\$697,285.25	\$1,005,361.82	\$20,678.07	\$87,700.04	\$981,551.10
Enterprise Funds							
Water	\$182,721.80	\$222,585.00	\$259,012.86	\$146,293.94	\$31,079.04	\$22,292.33	\$191,508.51
Sewer	\$346,310.44	\$73,227.87	\$78,332.34	\$341,205.97	\$10,011.47	\$10,498.41	\$345,823.50
Storm Water	\$99,350.11	\$70,582.60	\$69,848.44	\$100,084.27	\$11,477.00	\$62,796.09	\$48,031.02
Total (Enterprise Funds)	\$628,382.35	\$366,395.47	\$407,193.64	\$587,584.18	\$52,567.51	\$95,586.83	\$585,363.03
Totals	\$1,676,955.42	\$1,020,469.47	\$1,104,478.89	\$1,592,946.00	\$73,245.58	\$183,286.87	\$1,566,914.13
Debt Summary	Remaining Balance 1/1/2022	Remaining Assessment 1/1/2022	Cash & Investments	2022 Principle Payments	Date Due	Maturity Date	Unfunded Balance 12/31/2022
1992 Streets	\$0.00	\$2,040.20	\$0.00	\$0.00	Paid	2012	(\$2,040.20)
2007 Streets	\$30,000.00	\$0.00	\$8,227.27	\$15,000.00	2/1/22 & 8/1/22	2/1/2023	\$6,772.73
Cert. of Indebtedness (2018 Pumper)	\$45,600.00	\$0.00	\$12,116.51	\$22,800.00	10/31/2022	10/31/2023	\$10,663.49
Water Wells Project	\$15,000.00	\$0.00	\$0.00	\$15,000.00	2/20/22 & 8/20/22	8/20/2022	\$0.00
Water Treatment Plant	\$172,000.00	\$0.00	\$0.00	\$56,000.00	2/20/22 & 8/20/22	8/20/2024	\$116,000.00
Sanitary Sewer Improvements	\$104,088.23	\$44,540.25	\$0.00	\$16,000.00	2/20/22 & 8/20/22	8/20/2030	\$43,547.98
Storm Water Improvements	\$730,000.00	\$0.00	\$0.00	\$60,000.00	2/1/22 & 8/1/22	2/1/2032	\$670,000.00
Water Tower/Water Main Imp Project	\$1,315,305.20	\$0.00	\$0.00	\$52,000.00	2/20/22 & 8/20/22	8/20/2044	\$1,263,305.20
Totals	\$2,411,993.43	\$46,580.45	\$20,343.78	\$236,800.00			\$2,108,269.20

Cash Flow Actuals

	January	February	March	April	May	June	Totals
Income							
Property Taxes	\$1,206.35	\$0.00	\$0.00	\$0.00	\$0.00	\$0.00	\$1,206.35
Licenses & Permits	\$613.67	\$0.00	\$0.00	\$0.00	\$0.00	\$0.00	\$613.67
Intergov't Receipts (Aids)	\$1,370.00	\$11,482.28	\$0.00	\$0.00	\$0.00	\$0.00	\$12,852.28
Charges for Services	\$0.00	\$0.00	\$0.00	\$0.00	\$0.00	\$0.00	\$0.00
Assessment Searches	\$0.00	\$0.00	\$0.00	\$0.00	\$0.00	\$0.00	\$0.00
Comm Ctr Rentals	\$0.00	\$0.00	\$0.00	\$0.00	\$0.00	\$0.00	\$0.00
Township Contribution	\$0.00	\$0.00	\$0.00	\$0.00	\$0.00	\$0.00	\$0.00
Fire Dept. Revenues	\$0.00	\$0.00	\$0.00	\$0.00	\$0.00	\$0.00	\$0.00
Park Rentals	\$0.00	\$0.00	\$0.00	\$0.00	\$0.00	\$0.00	\$0.00
Hall Receipts	\$150.00	\$0.00	\$0.00	\$0.00	\$0.00	\$0.00	\$150.00
Fines	\$0.00	\$90.00	\$0.00	\$0.00	\$0.00	\$0.00	\$90.00
Misc. Receipts	\$4,932.05	\$799.22	\$0.00	\$0.00	\$0.00	\$0.00	\$5,731.27
Other Receipts	\$0.00	\$0.00	\$0.00	\$0.00	\$0.00	\$0.00	\$0.00
Insurance Recovery	\$0.00	\$0.00	\$0.00	\$0.00	\$0.00	\$0.00	\$0.00
Interest Income (Checking)	\$18.84	\$15.66	\$0.00	\$0.00	\$0.00	\$0.00	\$34.50
Interest Income (Savings)	\$0.00	\$0.00	\$0.00	\$0.00	\$0.00	\$0.00	\$0.00
Transfers In	\$0.00	\$0.00	\$0.00	\$0.00	\$0.00	\$0.00	\$0.00
Transfers In (Savings)	\$0.00	\$0.00	\$0.00	\$0.00	\$0.00	\$0.00	\$0.00
Debt Proceeds/Sale of Assets	\$0.00	\$0.00	\$0.00	\$0.00	\$0.00	\$0.00	\$0.00
Special Assessments	\$0.00	\$0.00	\$0.00	\$0.00	\$0.00	\$0.00	\$0.00
Water Service	\$17,359.21	\$13,719.83	\$0.00	\$0.00	\$0.00	\$0.00	\$31,079.04
Sewer Service	\$5,219.55	\$4,791.92	\$0.00	\$0.00	\$0.00	\$0.00	\$10,011.47
Storm Water	\$6,032.30	\$5,444.70	\$0.00	\$0.00	\$0.00	\$0.00	\$11,477.00
	\$36,901.97	\$36,343.61	\$0.00	\$0.00	\$0.00	\$0.00	\$73,245.58
Expenses							
General Gov't	\$17,258.21	\$20,722.73	\$0.00	\$0.00	\$0.00	\$0.00	\$37,980.94
Public Safety	\$2,687.34	\$3,950.00	\$0.00	\$0.00	\$0.00	\$0.00	\$6,637.34
Public Works	\$4,302.11	\$15,970.07	\$0.00	\$0.00	\$0.00	\$0.00	\$20,272.18
Sanitation & Recycling	\$0.00	\$0.00	\$0.00	\$0.00	\$0.00	\$0.00	\$0.00
Park & Recreation	\$186.17	\$331.46	\$0.00	\$0.00	\$0.00	\$0.00	\$517.63
Hall Expenses	\$2,334.36	\$3,715.09	\$0.00	\$0.00	\$0.00	\$0.00	\$6,049.45
Debt Service	\$16,242.50	\$0.00	\$0.00	\$0.00	\$0.00	\$0.00	\$16,242.50
Capital Project Funds	\$0.00	\$0.00	\$0.00	\$0.00	\$0.00	\$0.00	\$0.00
Transfers Out	\$0.00	\$0.00	\$0.00	\$0.00	\$0.00	\$0.00	\$0.00
Transfer to Savings	\$0.00	\$0.00	\$0.00	\$0.00	\$0.00	\$0.00	\$0.00
Water	\$4,461.69	\$5,054.15	\$0.00	\$0.00	\$0.00	\$0.00	\$9,515.84
Sewer	\$6,708.07	\$3,136.67	\$0.00	\$0.00	\$0.00	\$0.00	\$9,844.74
Storm Water	\$0.00	\$0.00	\$0.00	\$0.00	\$0.00	\$0.00	\$0.00
	\$54,180.45	\$52,850.17	\$0.00	\$0.00	\$0.00	\$0.00	\$107,060.62
Other Expenses (DEBT)							
Wells/WTP Bonds	\$2,199.15	\$0.00	\$0.00	\$0.00	\$0.00	\$0.00	\$2,199.15
Water Imp. Bonds (2011)	\$4,186.41	\$0.00	\$0.00	\$0.00	\$0.00	\$0.00	\$4,186.41
Water Tower Project	\$6,390.93	\$0.00	\$0.00	\$0.00	\$0.00	\$0.00	\$6,390.93
Sewer Imp. Bonds (2011)	\$653.67	\$0.00	\$0.00	\$0.00	\$0.00	\$0.00	\$653.67
Storm Water Imp. Bonds (2011)	\$62,796.09	\$0.00	\$0.00	\$0.00	\$0.00	\$0.00	\$62,796.09
Total Other Expenses	\$76,226.25	\$0.00	\$0.00	\$0.00	\$0.00	\$0.00	\$76,226.25
Checking Balance	\$1,583,450.69	\$1,566,914.13	\$1,566,914.13	\$1,566,914.13	\$1,566,914.13	\$1,566,914.13	\$1,566,914.13
Net Income (Loss)	(\$93,504.73)	(\$16,536.56)	\$0.00	\$0.00	\$0.00	\$0.00	(\$110,041.29)

**City of Hamburg
Time-Off Request Form**

Today's Date: 3-15-22

Employee Name: Greg Schultz

Dates Requesting Off: March 25

How many **Vacation** hours will be used? 1

How many **Compensation** hours will be used? 0

Is there a **Holiday** during your time off? No

Will there be any time off **without pay**? No

Will there be any scheduled **Sick Leave** used? No

Are you requesting more than three consecutive days off? No

- If yes, you must receive City Council approval.

City Council Approval

Date of Council Meeting: _____

Was vacation request approved? _____

- If no, reason request was denied: _____

Greg Schultz 3-15-22
Employee Signature Date

Jimmy Luchan 3-15-22
City Clerk/Treasurer Date

Mayor Date

CITY OF HAMBURG
City Clerk/Treasurer – PO Box 248
181 Broadway Ave., Hamburg, MN 55339

*City Office: (952) 467-3232 TDD: 711 Email: CityAdmin@CityofHamburgmn.com
City Website: CityofHamburgmn.com*

March 22, 2022

The Honorable Pete Buttigieg
Secretary, US Department of Transportation
1200 New Jersey Ave, SE
Washington, DC 20590

Dear Secretary Buttigieg,

The City of Hamburg is pleased to support the US Highway 212 Rural Freight Mobility and Safety Project for consideration of federal financial assistance under US Department of Transportation (DOT) Discretionary Grant Programs. This critical project expands five miles of US Highway 212 in Carver County, Minnesota from a two-lane undivided rural highway to a four-lane divided expressway facility extending from the City of Norwood Young America (County Highway 34) to the City of Cologne (County Highway 36). Carver County and MnDOT completed extensive corridor planning and are partnering on project development efforts to bring forward this innovative, cost-effective approach to expand US Highway 212.

The corridor is part of the National Highway System and is one of the most important economic and freight highway corridors in the State of Minnesota and the Upper Midwest region, connecting the Twin Cities to South Dakota and beyond. US Highway 212 is identified by the Minnesota DOT (MnDOT) in the Minnesota State Freight Investment Plan as a Critical Rural Freight Corridor. The corridor provides a connection for agricultural and industrial traffic to and from the Twin Cities Metropolitan area, which is emphasized by the Metropolitan Council's prioritization of the highway as a "Tier One Truck Corridor".

The US Highway 212 Rural Freight Mobility and Safety Project addresses serious safety, access, and mobility issues and meets and exceeds the priority objectives of the DOT's grant programs. Most significantly, the project will benefit the highway freight network by addressing deficiencies on a Critical Rural Freight Corridor, implementing significant highway safety measures, improving the state of good repair for National Highway System infrastructure not fully reconstructed since 1930, and strengthening local and regional economic competitiveness and vitality by realizing the vision of a reliable and connected freight transportation system.

The City of Hamburg endorses and supports Carver County's application to US DOT Discretionary Grant Programs for the US Highway 212 Rural Freight Mobility and Safety Project and urges decision makers to prioritize the project for grant funding.

Sincerely,

Chris Lund
Mayor



"The City of Hamburg is an Equal Opportunity Employer and Provider."

NOTICE OF PUBLIC HEARING
COUNTY OF CARVER
CHASKA, MINNESOTA

Appeal for a Variance

NOTICE IS HEREBY GIVEN that on Wednesday, the 6th day of April 2022, as soon as possible after 7:00 p.m. upstairs in the Human Services Bldg (602) in the Commissioner's Meeting Room of the Carver County Government Center, Chaska, Minnesota, the Carver County Board of Adjustment will hold a public hearing to consider the application of Emanuel Lutheran Church for a variance pursuant to Chapter 154 (Sign Ordinance) of the County Ordinance.

The application is being made for the following described property (full legal description is on file with the application):

Approx. 16.63 acres in the NE $\frac{1}{4}$ of NW $\frac{1}{4}$ of Section 32, Young America Township
Address: 18175 County Rd 50

If approved, this variance would allow for the placement of a 94-square foot sign with electronic changeable text capability. The County Sign Ordinance allows a maximum of 32 square feet of sign surface area (2-sided) and a total of 36 square feet of aggregate signage for any parcel. Electronic changeable copy signs are unauthorized.

All persons interested are invited to attend the hearing and be heard on this matter. Prior to the meeting, anyone who wishes to provide written comments related to the request may email them to: landmanagement@co.carver.mn.us or submit by mail to:

Dept. of Land Management
Carver County Government Center
600 East Fourth Street
Chaska, MN 55318-2102

Carver County Board of Adjustment
By: Jason Mielke
Land Management Department Manager
(952) 361-1817

Date to Publish: March 24, 2022

Chaska Herald, News & Times

To be billed to: Public Services Division
Land Management Department at the address above

END

THIS IS NOT A SCHEDULED RECORD IN THE
 PUBLIC RECORDS OF THE COUNTY OF
 HANBURG, MISSOURI. IT IS THE PROPERTY OF
 THE MISSOURI DEPARTMENT OF REVENUE AND
 IS NOT TO BE REPRODUCED OR
 TRANSMITTED IN ANY FORM OR BY ANY
 MEANS, ELECTRONIC OR MECHANICAL,
 INCLUDING PHOTOCOPYING, RECORDING,
 OR BY ANY INFORMATION STORAGE AND
 RETRIEVAL SYSTEM.

N 1/2 SEC. 32, T.115, R.26

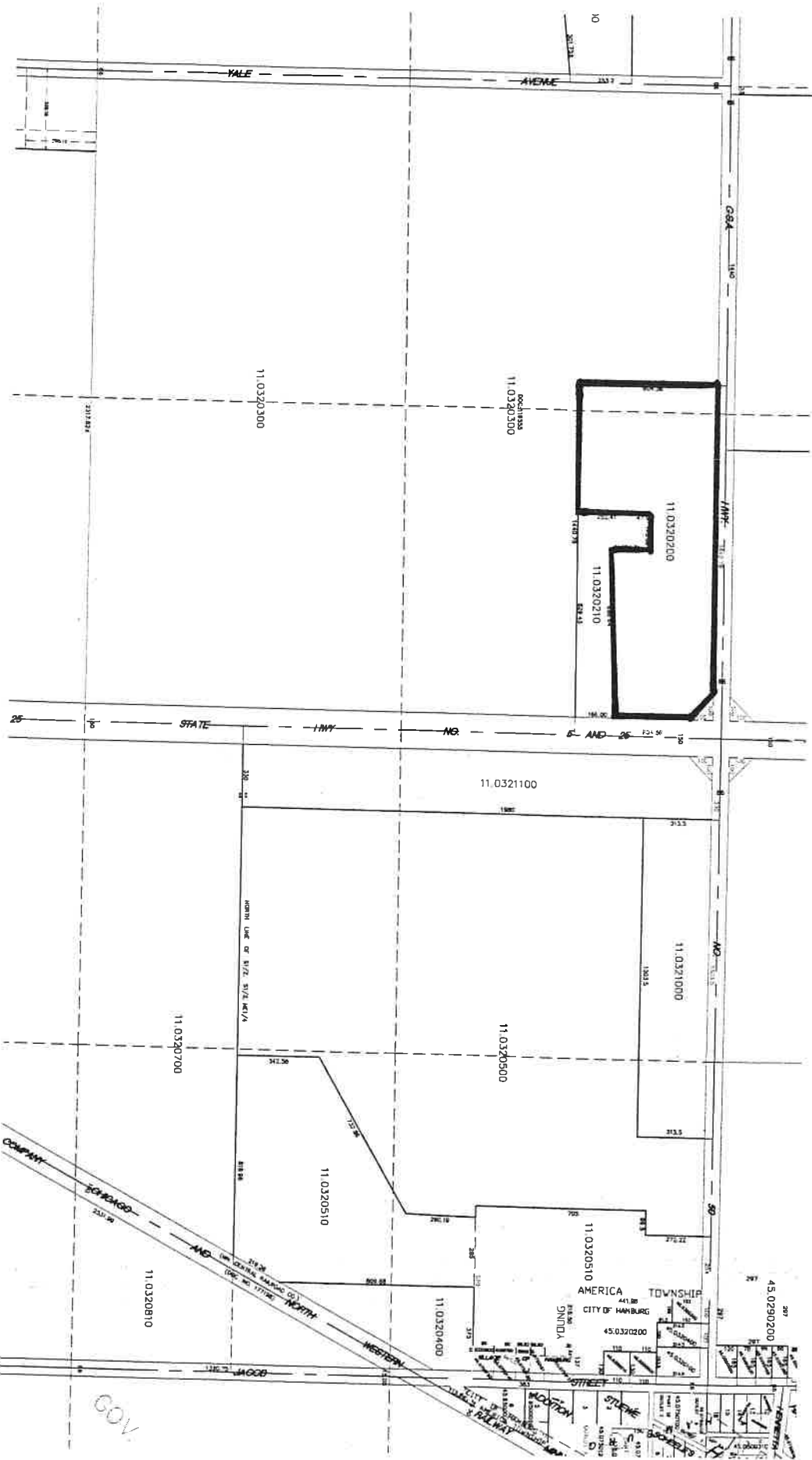

Surveying & Mapping Office
 Carroll County, Mo.
 600 East Fourth Street
 Chariton, MO 64601
 Phone: 660-325-2222
 Fax: 660-325-2223
 Website: www.carrollcountymissouri.gov



Jeremy Gruenhagen <cityadmin@cityofhamburgmn.com>

2022 Street Project - Maria 7 Louisa

Brody Bratsch <bbratsch@sehinc.com>

Mon, Jan 24, 2022 at 4:53 PM

To: "Jeremy Gruenhagen (cityadmin@cityofhamburgmn.com)" <cityadmin@cityofhamburgmn.com>

Cc: Justin Black <jblack@sehinc.com>

Jeremy,

Here's a simple map and cost estimate for a Maria and Louisa 2022 Street Improvement Project.

The cost estimate includes:

- 2" full width mill
- 300' of curb and gutter replacement (this may be high, can reevaluate when the snow is gone)
- Valley gutter replacement
- Some patching in the worst condition areas.
- Seal coat over milled surface (Called a Texas Underseal, studies show it helps prevent the stress cracks from coming through the new pavement early)
- 2" new bituminous overlay

If these numbers look good to you, let me know and then we will prepare an agreement for completing the plans and specs and bidding services for the project. We can have this agreement ready for you to have on the agenda for the February 8th council meeting in which either Justin or myself can be in attendance.

Thanks!

Brody Bratsch, PE (MN)

Project Engineer

320.204.0219 direct | 320.223.8418 mobile

Short Elliott Hendrickson, Inc.

Building a Better World for All of Us™

2 attachments

**2022 Maria_Lousia Mill-11x8EX.pdf**

842K

**Hamburg 2022 St Imp Proj Estimate_Summary.pdf**

- EXISTING**
- RIGHT OF WAY
 - PERMANENT EASEMENT
 - HORIZONTAL CONTROL POINT
 - BENCHMARK
 - SURVEY MARKER
 - SOIL BORING
 - SANITARY SEWER AND MANHOLE
 - FORCE MAIN AND LIFT STATION
 - SANITARY SEWER SERVICE A CLEANOUT
 - WATER MAIN, HYDRANT, VALVE AND MANHOLE
 - WATER SERVICE AND CURB STOP BOX
 - STORM SEWER MANHOLE AND CATCH BASIN
 - CULVERT AND APRON ENDWALL
 - GAS MAIN, VALVE, VENT AND METER
 - HANDHOLE
 - BURIED FIBER OPTIC CABLE AND MANHOLE
 - BURIED PHONE CABLE, PEDESTAL AND MANHOLE
 - BURIED TV CABLE, PEDESTAL AND MANHOLE
 - BURIED ELECTRIC CABLE, PEDESTAL, MANHOLE, OVERHEAD WIRE, POLE AND GUY WIRE
 - LIGHT POLE
 - TRAFFIC SIGNAL
 - STREET NAME SIGN
 - SIGN (NON STREET NAME)
 - RAILROAD TRACKS
 - REGULOUS AND CONIFEROUS TREE
 - BUSH / SHRUB AND STUMP
 - EDGE OF WOODED AREA
 - WETLAND
 - BUILDING
 - FENCE (UNIDENTIFIED)
 - BARBED WIRE FENCE
 - CHAIN LINK FENCE
 - ELECTRIC WIRE FENCE
 - WOOD FENCE
 - WOVEN WIRE FENCE
 - PLATE BEAM GUARDRAIL
 - CABLE GUARDRAIL
 - POST / BOLLARD
 - RETAINING WALL
- PROPOSED**
- STREET CENTERLINE
 - RIGHT-OF-WAY
 - PERMANENT EASEMENT
 - TEMPORARY EASEMENT
 - CONSTRUCTION LIMITS
 - 3 SANITARY SEWER BUILDUP AND MANHOLE
 - FORCE MAIN
 - SANITARY SERVICE AND CLEANOUT
 - WATER MAIN, TEE, HYDRANT, BUILDUP AND VALVE
 - WATER VALVE MANHOLE, REDUCER, BRAD AND CROSS
 - WATER SERVICE AND CURB STOP BOX
 - STORM SEWER MANHOLE AND CATCH BASIN
 - CULVERT AND APRON ENDWALL
 - DRAIN TILE
 - RAPIRAP
 - STREET NAME SIGN
 - SIGN (NON STREET NAME)
 - RETAINING WALL

CITY OF HAMBURG, MINNESOTA

CONSTRUCTION PLANS FOR

2022 MILL AND OVERLAY PROJECT

REMOVALS, MILLING, BITUMINOUS UNDERSEAL, BITUMINOUS PAVEMENT, CONCRETE CURB AND GUTTER

HAMBU 166227

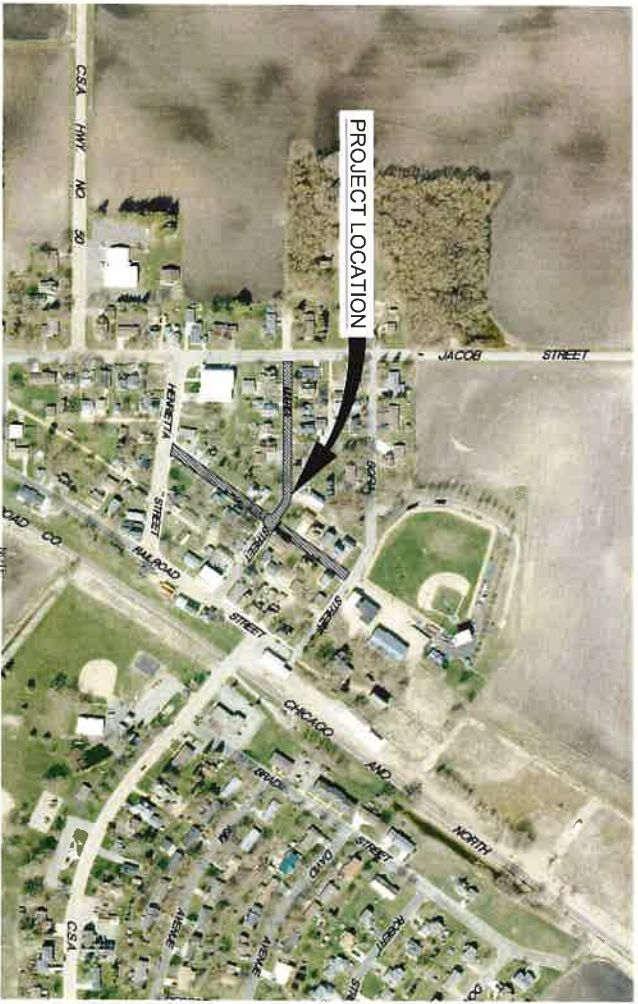

NOTE:
 THE SUBSURFACE UTILITY QUALITY INFORMATION IN THIS PLAN IS LEVEL D. THIS UTILITY QUALITY LEVEL WAS DETERMINED ACCORDING TO THE STANDARD SPECIFICATIONS FOR ROAD AND RAILROAD CONSTRUCTION FOR THE COLLECTION AND DEPOSITION OF EXISTING SUBSURFACE UTILITY DATA. THE CONTRACTOR SHALL CALL THE GOPIHER STATE ONE CALL SYSTEM AT 811 BEFORE COMMENCING EXCAVATION.



CONVENING SPECIFICATIONS

THE ADAPTATION OF THE SPECIFICATIONS FOR CONSTRUCTION SHALL BE IN ACCORDANCE WITH THE SPECIFICATIONS FOR CONSTRUCTION SHALL GOVERN EXCEPT AS MODIFIED BY THE SPECIFICATIONS FOR THIS PROJECT.

ALL MATERIALS AND METHODS SHALL BE AS SPECIFIED IN THE SPECIFICATIONS FOR CONSTRUCTION. THE CONTRACTOR SHALL BE RESPONSIBLE FOR OBTAINING ALL NECESSARY PERMITS AND APPROVALS FROM THE CITY OF HAMBURG.

SHEET NO.	DESCRIPTION
1	TITLE SHEET
2	STATEMENT OF ESTIMATED QUANTITIES
3	CONSTRUCTION PLAN
4	DETAILS AND TYPICAL SECTION
5	REMOVALS
6	CONSTRUCTION PLAN

THIS PLAN CONTAINS 6 SHEETS.



HAMBURG, MINNESOTA

PROJECT LOCATION

SEH
 SOLUTIONS ENGINEERING & ARCHITECTURE
 1500 W. WASHINGTON AVENUE
 MINNEAPOLIS, MN 55402
 TEL: 612.338.1100
 WWW.SEH.COM

DESIGNED BY: [Signature]
 DRAWN BY: [Signature]
 CHECKED BY: [Signature]
 APPROVED BY: [Signature]

DATE: 03/27/2022

PROJECT NO: 166227

SHEET NO. 1 OF 6

SEH Project
 Design By: DRS
 Checked By: DRS
 Date: 1/11/22

Project Name:
 Description:
 Title:

Rev #

Project Name:
 Description:
 Title:



Project Name:
 Description:
 Title:

2022 MILL AND OVERLAY PROJECT
 HAMBURG, MINNESOTA

STATEMENT OF
 ESTIMATED QUANTITIES

STATEMENT OF ESTIMATED QUANTITIES									
ITEM #	DESCRIPTION	UNIT	PROJECT TOTAL		MARIA AVE		LOUISA ST		REMARKS
			Est. Qty.	Qty. To Date	Est. Qty.	Qty. To Date	Est. Qty.	Qty. To Date	
STREET, CURB AND GUTTER, DRAINAGE PIPE, SIDEWALKS									
2071.501	MOBILIZATION	LUMP SUM	1.0		0.5		0.5		
2104.503	REMOVE CONCRETE CURB AND GUTTER	LN FT	230.0		60.0		150.0		
2104.503	SAWING BITUMINOUS PAVEMENT (FULL DEPTH)	LN FT	310.0		250.0		260.0		
2104.503	SAWING CONCRETE PAVEMENT (FULL DEPTH)	LN FT	40.0		20.0		20.0		
2104.504	REMOVE CONCRETE VALLEY GUTTER	SO YD	25.0		25.0		0.0		
2104.504	REMOVE BITUMINOUS PAVEMENT	SO YD	270.0		120.0		150.0		
2121.51	STREET SWEEPER (WITH BROOM PICKUP)	HOUR	6.0		4.0		4.0		
2212.504	MILL BITUMINOUS SURFACE (2")	SQ YD	4,010.0		1,800.0		2,210.0		
2201.602	DRILL AND GROUT DOWEL BAR (EPOXY COATED)	LN FT	40.0		1,643.0		20.0		CURBS
2201.603	JOINT ADHESIVE (MASTIC)	EACH	3,000.0		1,800.0		1,200.0		
2201.504	BITUMINOUS SEAL COAT	SO YD	4,015.0		2,215.0		2,200.0		
2200.509	TYPE SP 9.5 WEARING COURSE MIX (2.0) (SPRUE/200)	TON	530.0		280.0		250.0		
2200.509	TYPE SP 9.5 WEARING COURSE MIX (2.0) (SPRUE/200) (PATCHING)	TON	40.0		21.0		20.0		
2204.602	ADJUST GATE VALVE BOX OR MANHOLE CASTING (WATER MAIN)	EACH	5.0		4.0		1.0		
2511.503	CURB/STREET CURB & GUTTER B&E	LN FT	2,200.0		80.0		1,900.0		
2511.504	7" CONCRETE DRIVEWAY PAVEMENT W/17" AGGREGATE BASE	SO YD	28.0		28.0		0.0		
2511.601	8" CONCRETE VALLEY GUTTER	SO YD	25.0		24.0		0.0		
2563.601	TRAFFIC CONTROL	LUMP SUM	1.0		0.5		0.5		
2575.604	TURF RESTORATION	50 YD	80.0		30.0		50.0		
2575.607	ELECTRICAL RESTORATION (LVI)	CU YD	8.0		3.0		5.0		
STORM SEWER									
2206.302	ADJUST FRAME AND RING CASTING (STORM)	EACH	1.0		0.0		0.0		
2272.502	STORM DRAIN INLET PROTECTION	EACH	10.0		5.0		5.0		
SANITARY SEWER									
2102.502	ADJUST FRAME AND RING CASTING (SANITARY)	EACH	4.0		0.0		0.0		
2102.502	EXTERNAL MANHOLE SEAL (SANITARY)	EACH	4.0		4.0		0.0		FOR SANITARY SEWER MANHOLES

GENERAL NOTES

CONTRACTOR SHALL PROVIDE TRAFFIC CONTROL.
 PROTECT ALL FACILITIES NOT SPECIFIED FOR REMOVAL.
 INSTALL STORM DRAIN INLET PROTECTION AT ALL STORM STRUCTURES AS DIRECTED BY ENGINEER PRIOR TO START OF WORK.
 EXCAVATION FOR VALLEY GUTTER AND CONCRETE DRIVEWAYS SHALL BE CONSIDERED INCIDENTAL.
 SAWCUT BITUMINOUS AND CONCRETE AS DIRECTED BY THE ENGINEER IN THE FIELD CONCRETE REMOVAL IN FIELD SHOULD BE DONE TO NEAREST JOINT IF A SAWCUT IS REQUIRED TO PRESERVE ADJACENT CONCRETE IT SHALL BE INDENTIFIED.
 DURING THE CONSTRUCTION OPERATIONS, IF ANY MATERIAL IS DEPOSITED IN THE FLOW LINE OF ANY GUTTERS OR DRAINAGE STRUCTURE SUCH THAT THE FLOW OF WATER IS OBSTRUCTED, IT SHALL BE REMOVED AT THE CLOSE OF EVERY WORKING DAY. AT THE CONCLUSION OF OPERATIONS ALL DRAINAGE FACILITIES SHALL BE CLEAN AND FREE OF ANY OBSTRUCTIONS. THE COST OF THIS WORK SHALL BE INDENTIFIED.
 QUALITY CONTROL INCLUDING COMPACTION TESTING SHALL BE IN ACCORDANCE WITH THE PROJECT MANUAL. ALL COMPACTION SHALL MEET THE RECOMMENDATIONS CONTAINED IN THE MATERIAL TESTING SOILS REPORTS.

BASIS FOR ESTIMATED QUANTITIES
BITUMINOUS MATERIAL: WEAR COURSE = 110 LB PER SY PER IN TACK COAT: 0.10 GAL PER SY - OVERLAY

WARNING NOTE

THE LOCATIONS OF ALL EXISTING UTILITY INSTALLATIONS AS SHOWN ON THE PLANS ARE APPROXIMATE THERE MAY BE OTHER UTILITY INSTALLATIONS AND RELOCATIONS WITHIN THE PROJECT AREA NOT SHOWN ON THE PLANS.
 THE SUBSURFACE UTILITY INFORMATION IN THIS PLAN IS UTILITY QUALITY LEVEL D. THIS QUALITY LEVEL WAS OBTAINED BY FIELD SURVEYING TO PREVIOUSLY EXISTING TO PREVIOUSLY EXISTING STANDARD SCHEDULES FOR THE COLLECTION AND DEPOSITION OF EXISTING SUBSURFACE UTILITY DATA.
 CONTRACTOR SHALL CONTACT "GOPHER ONE" FOR LOCATION OF ALL UNDERGROUND WIRES, CABLES, CONDUITS, PIPES, VALVES, MANHOLES, OR OTHER BURIED STRUCTURE BEFORE DIGGING (1.800.252.1199).
 CONTRACTOR SHALL REPAIR ANY OF THE ABOVE WHICH ARE REMOVED OR DAMAGED DURING CONSTRUCTION AT NO COST TO THE OWNER.

TURF RESTORATION

ALL EROSION AND SEDIMENT CONTROL MEASURES SHALL BE INSTALLED PRIOR TO DISTURBANCE COMMENCING.
 AS DISTURBED AREAS BEHIND THE CURB SHALL BE RESTORED WITH TURF RESTORATION (S7).
 AS AREAS OUTSIDE THE STREETS ARE GRADED, PROVIDE 4 INCHES BOWLEWARD TOP SOIL.
 TO MINIMIZE EROSION ON ALL OTHER AREAS, THE CONTRACTOR SHALL PROCEED WITH TURF RESTORATION (SEED AND MULCH) WITHIN ONE WEEK OF COMPLETION OF ALL FINAL GRADES.
 RATES OF APPLICATION
 APPLY 20-0-10 (PHOSPHORUS FREE) FERTILIZER ON ALL TURF RESTORATION AREAS AT THE RATE OF 10 POUNDS PER 1000 SQUARE FEET.

SET Project Drawn By: DHI Designed By: DHI Checked By: DHI	Revised: 1/16/27 Rev #	Project Name Description Utlid Rev #	Project Name Description Date
PROJECT OWNER: 2022 MILL AND OVERLAY PROJECT HAMBURG, MINNESOTA		CONSTRUCTION NOTES	
3 of 6			

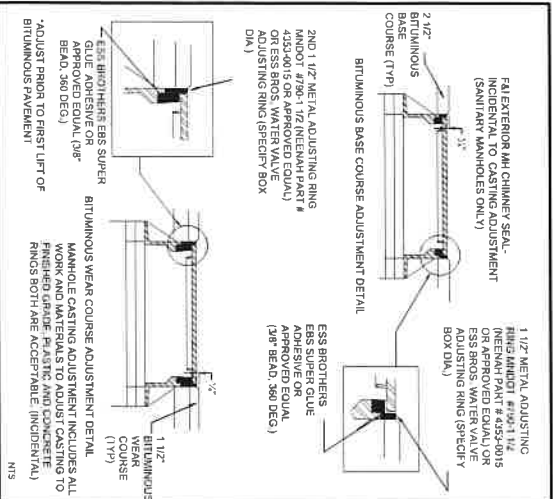

MANHOLE CASTING / WATER VALVE ADJUSTMENTS

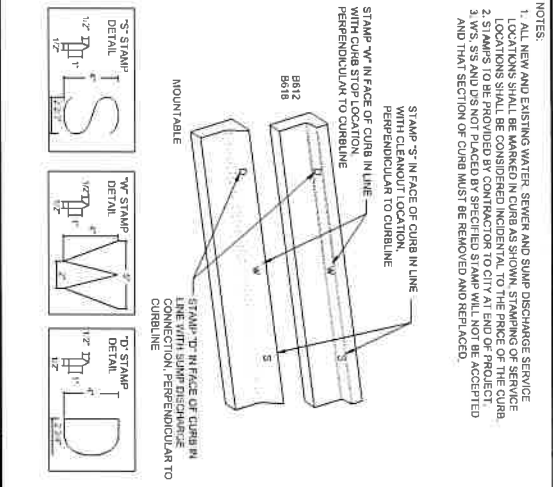

WATER SEWER AND SUMP DISCHARGE SERVICE LOCATION STAMP IN CURB

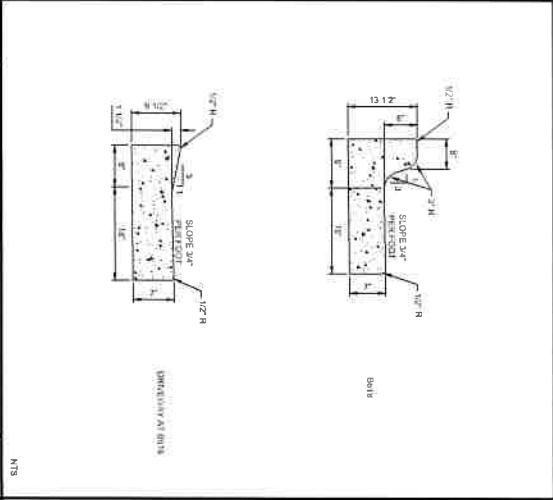

CURB AND GUTTER

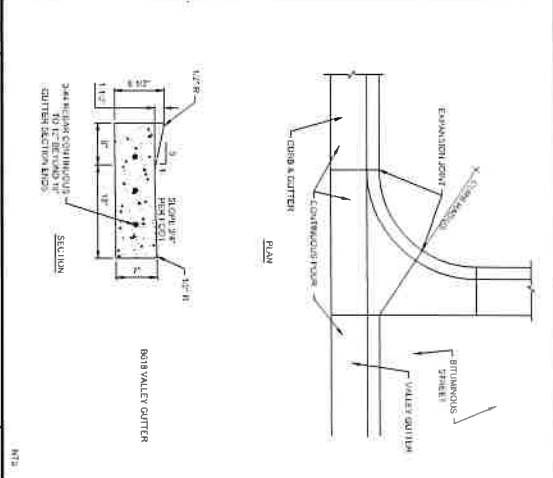

CONCRETE VALLEY GUTTER

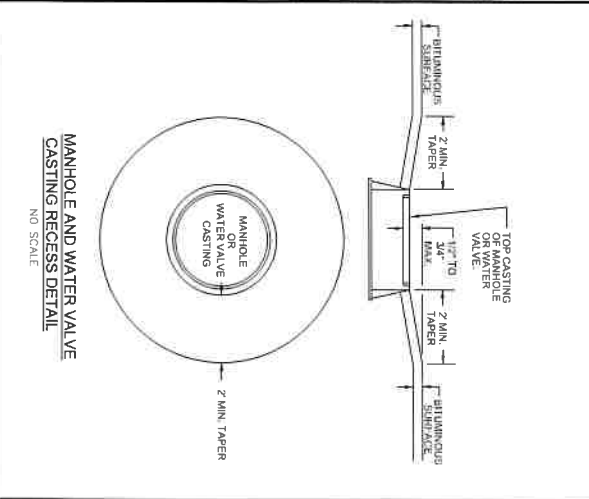

MANHOLE AND WATER VALVE CASTING RECESS DETAIL

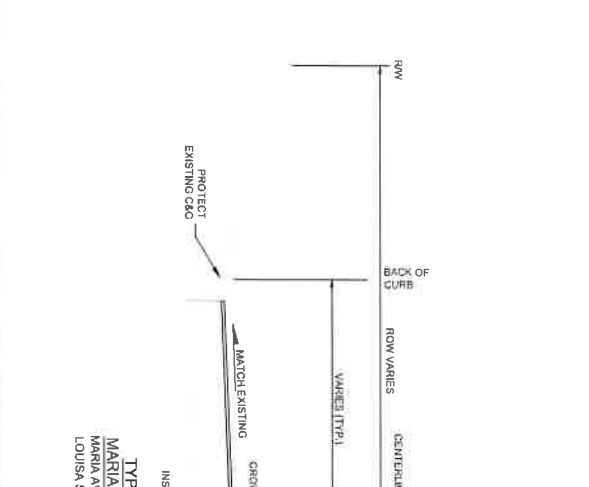

TYPICAL SECTION
 MARIA AVE - LOUISA ST
 MARIA AVE - 31FT BOC TO BOC
 LOUISA ST - 38FT BOC TO BOC

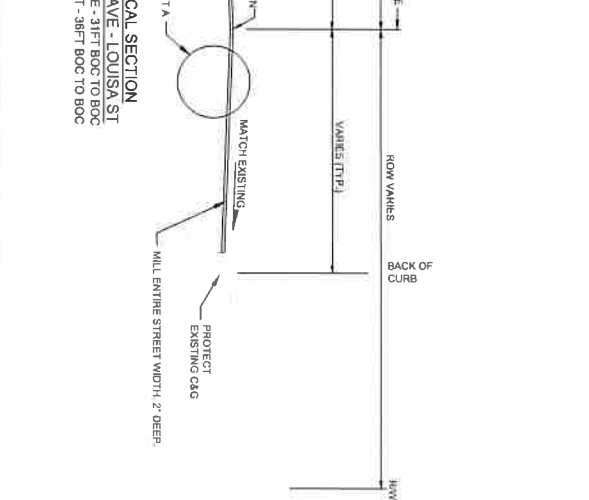

INSET A - 2" MILL AND OVERLAY

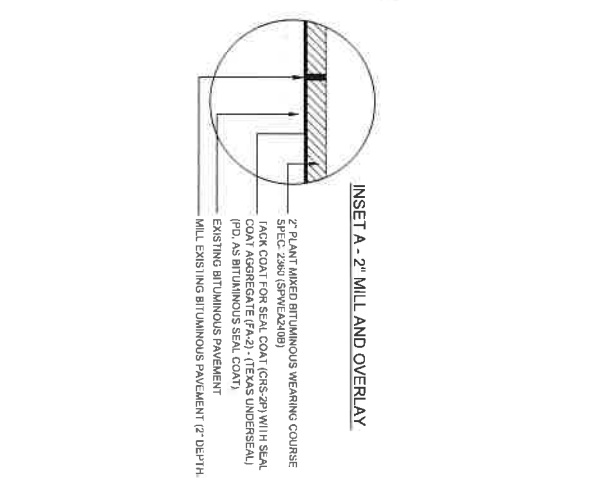

DETAILS TYPICAL SECTION

SET Project: HAMBURG 16-02-27 Drawn By: DBB Designed By: DBB Checked By: DBB	Revision: Rev. # Description:	Date:	PROJECT CLIENT: THE CITY OF HAMBURG, MINNESOTA PROJECT ADDRESS: 1000 MILL AVE, HAMBURG, MN 55030 CONTRACT NO.: 16-02-27 SHEET NO.: 4131	2022 MILL AND OVERLAY PROJECT HAMBURG, MINNESOTA	SHEET NO.: STR-19	SHEET NO.: STR-21
---	----------------------------------	-------	--	--	-------------------	-------------------

SEH Project #	HAMBURG 162275	Sheet #	1
Drawn By	DMB	Revision	
Checked By	MLB	Project Name	2022 MILL AND OVERLAY PROJECT
		Location	HAMBURG, MINNESOTA
		Scale	AS SHOWN
		Author	SEH
		Client	SEH
		Project	2022 MILL AND OVERLAY PROJECT
		Location	HAMBURG, MINNESOTA
		Sheet	MARIA AVE AND LOUISA ST
		Page	5 of 5

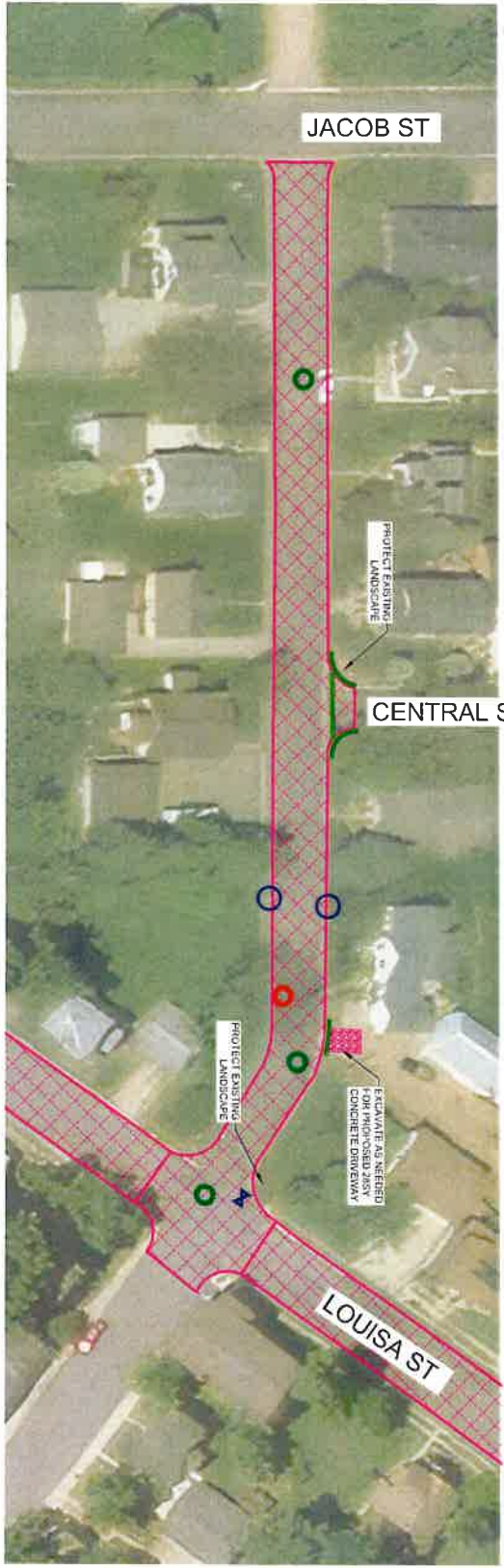

MARIA AVE
LOUISA ST

REMOVAL LEGEND:

	MILL BITUMINOUS SURFACE (SEE SHEET 4 FOR DETAIL)
	ADJUST GATE VALVE BOX
	ADJUST MANHOLE (STORM)
	ADJUST MANHOLE (SANITARY)
	REMOVE CURB AND CUTTER
	INLET PROTECTION

NOTE:
SPOT REPLACEMENT OF CURB AND CUTTER AND BITUMINOUS PATCHING AREAS WILL BE MARKED FOR REMOVAL BY ENGINEER IN THE FIELD.

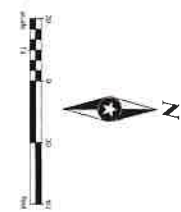

Client Request	HAMBURG 162275	Project Name	2022 MILL AND OVERLAY PROJECT
Drawn By	EPB	Project Location	HAMBURG, MINNESOTA
Checked By	EPB	Scale	
DATE	3/16/2022	Revision	



PROJECT: 2022 MILL AND OVERLAY PROJECT
 SHEET: 13-Civil\csp\sheet\HA16227PL.dwg
 DATE: 3/16/2022
 DRAWN BY: EPB
 CHECKED BY: EPB

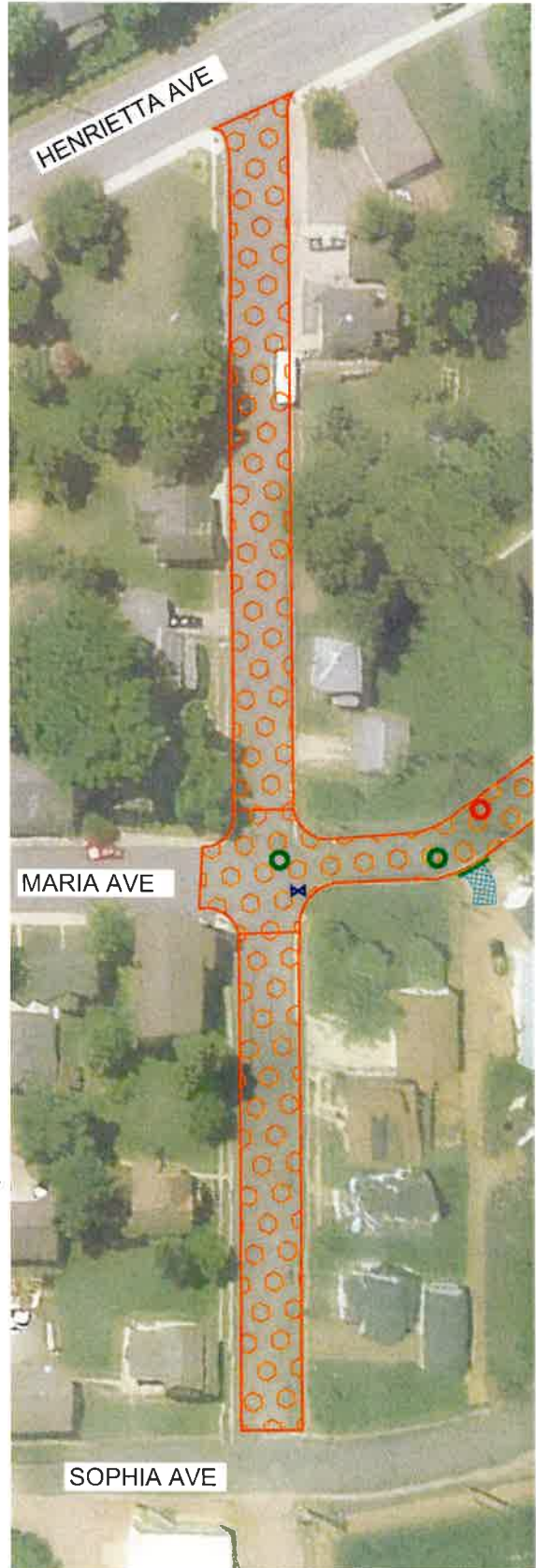
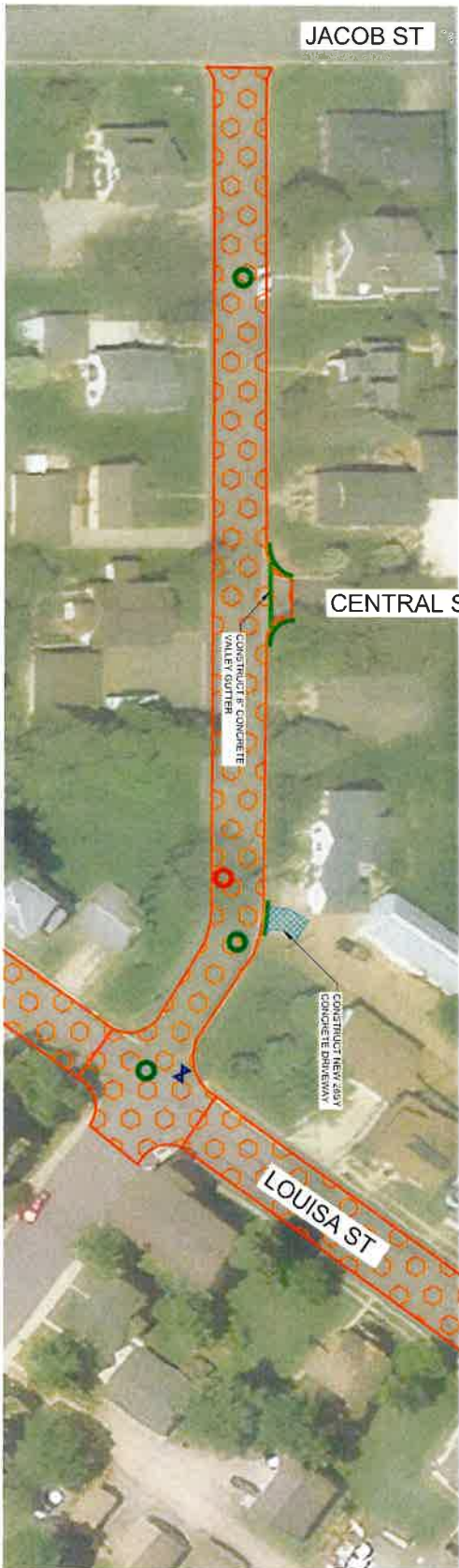

LEGEND:

-  CONSTRUCT NEW BITUMINOUS OVERLAY (SEE SHEET 4)
-  NEW CURB AND GUTTER
-  ADJUST GATE VALVE
-  ADJUST MANHOLE (STORM)
-  ADJUST MANHOLE (SANITARY)

NOTE: PER AGREEMENT OF CURB AND GUTTER AND BITUMINOUS PATCHING ARE TO BE MARKED IN FIELD BY ENGINEER

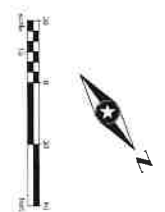
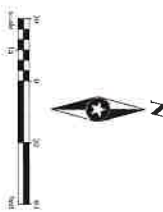

**ENGINEER'S ESTIMATE
2022 STREET IMPROVEMENT PROJECT
HAMBURG, MINNESOTA
SEH NO. HAMBU 166227
MARCH 22, 2022**

PROJECT AREA 2" Mill, Seal Coat, and Overlay	TOTAL ESTIMATED PROJECT COST
Maria Ave	\$87,000
Louisa St	\$85,000
TOTAL	\$172,000

ENGINEER'S ESTIMATE
 2022 STREET IMPROVEMENT PROJECT
 HAMBURG, MINNESOTA
 SEH NO. HAMBUR 166227
 MARCH 18, 2022

				BASIS OF ESTIMATED QUANTITIES			
MILL AREA	SY	1800	SY	2215	SY		
WEAR LIFT	IN	2	IN	2	IN		
PATCHING AREA	SY	120	SY	150	SY		
PATCHING LIFT	IN	2	IN	2	IN		

Item No.	Item Description	Unit	Est. Qty.	Est. Unit Price	Est. Cost	PROJECT TOTAL		MARIA AVE		LOUISA ST	
						Est. Qty.	Est. Cost	Est. Qty.	Est. Cost	Est. Qty.	Est. Cost
STREET, CURB AND GUTTER, DRAINAGE PIPE, SIDEWALKS											
2021.501	MOBILIZATION	LUMP SUM	1.00	\$10,000.00	\$10,000.00						
2104.503	REMOVE CONCRETE CURB AND GUTTER	LIN FT	230.00	\$12.00	\$2,760.00	0.50	\$5,000.00	0.50	\$5,000.00	150.0	\$1,800.00
2104.503	SAWING BITUMINOUS PAVEMENT (FULL DEPTH)	LIN FT	510.00	\$2.00	\$1,020.00	250.0	\$500.00	250.0	\$500.00	250.0	\$520.00
2104.503	SAWING CONCRETE PAVEMENT (FULL DEPTH)	LIN FT	40.00	\$4.00	\$160.00	20.0	\$80.00	20.0	\$80.00	20.0	\$80.00
2104.504	REMOVE CONCRETE VALLEY GUTTER	SO YD	25.00	\$20.00	\$500.00	25.0	\$500.00	0.0	\$0.00	0.0	\$0.00
2104.504	REMOVE BITUMINOUS PAVEMENT	SO YD	270.00	\$5.00	\$1,350.00	120.0	\$600.00	150.0	\$750.00	150.0	\$750.00
2123.610	STREET SWEEPER (WITH BROOM PICKUP)	HOUR	8.00	\$125.00	\$1,000.00	4.0	\$500.00	4.0	\$500.00	4.0	\$500.00
2232.504	MILL BITUMINOUS SURFACE (2")	SO YD	4,015.00	\$6.00	\$24,090.00	1,800.0	\$10,800.00	2,215.0	\$13,290.00	2,215.0	\$13,290.00
2301.602	DRILL AND GROUT DOWEL BAR (EPOXY COATED)	EACH	40.00	\$12.00	\$480.00	20.0	\$240.00	20.0	\$240.00	20.0	\$240.00
2331.603	JOINT ADHESIVE (MASTIC)	LIN FT	3,010.00	\$1.00	\$3,010.00	1,643.0	\$1,643.00	1,367.0	\$1,367.00	1,367.0	\$1,367.00
2355.504	BITUMINOUS SEAL COAT	SO YD	4,015.00	\$2.00	\$8,030.00	1,800.0	\$3,600.00	2,215.0	\$4,430.00	2,215.0	\$4,430.00
2360.509	TYPE SP 9.5 WEARING COURSE MIX (2B) (SPWEA240B)	TON	530.00	\$102.00	\$54,060.00	240.0	\$24,480.00	290.0	\$29,580.00	290.0	\$29,580.00
2360.509	TYPE SP 9.5 WEARING COURSE MIX (2B) (SPWEA240B) (PATCHING)	TON	40.00	\$180.00	\$7,200.00	20.0	\$3,600.00	20.0	\$3,600.00	20.0	\$3,600.00
2504.602	ADJUST GATE VALVE BOX OR MANHOLE CASTING (WATER MAIN)	EACH	5.00	\$300.00	\$1,500.00	4.0	\$1,200.00	1.0	\$300.00	1.0	\$300.00
2531.503	CONCRETE CURB & GUTTER B618	LIN FT	230.00	\$34.00	\$7,820.00	80.0	\$2,720.00	150.0	\$5,100.00	150.0	\$5,100.00
2531.504	7" CONCRETE DRIVEWAY PAVEMENT W/1/2" AGGREGATE BASE	SO YD	28.00	\$130.00	\$3,640.00	28.0	\$3,640.00	0.0	\$0.00	0.0	\$0.00
2531.604	8" CONCRETE VALLEY GUTTER	SO YD	25.0	\$140.00	\$3,500.00	25.0	\$3,500.00	0.0	\$0.00	0.0	\$0.00
2563.601	TRAFFIC CONTROL	LUMP SUM	1.00	\$2,000.00	\$2,000.00	0.50	\$1,000.00	0.50	\$1,000.00	0.50	\$1,000.00
2575.604	TURF RESTORATION	SO YD	80.00	\$8.00	\$640.00	30.0	\$240.00	50.0	\$400.00	50.0	\$400.00
2575.607	SELECT TOPSOIL BORROW (LV)	CU YD	8.00	\$60.00	\$480.00	3.0	\$180.00	5.0	\$300.00	5.0	\$300.00
STREET, CURB AND GUTTER, DRAINAGE PIPE, SIDEWALKS SUBTOTAL					\$133,240.00		\$64,983.00		\$68,257.00		
STORM SEWER											
2405.502	ADJUST FRAME AND RING CASTING (STORM)	EACH	1.0	\$700.00	\$700.00	1.0	\$700.00	0.0	\$0.00	0.0	\$0.00
2573.502	STORM DRAIN INLET PROTECTION	EACH	10.0	\$140.00	\$1,400.00	5.0	\$700.00	5.0	\$700.00	5.0	\$700.00
STORM SEWER SUBTOTAL					\$2,100.00		\$1,400.00		\$700.00		\$700.00
SANITARY SEWER											
2405.502	ADJUST FRAME AND RING CASTING (SANITARY)	EACH	4.0	\$700.00	\$2,800.00	4.0	\$2,800.00	0.0	\$0.00	0.0	\$0.00
2506.602	EXTERNAL MANHOLE SEAL (SANITARY)	EACH	4.0	\$250.00	\$1,000.00	4.0	\$1,000.00	0.0	\$0.00	0.0	\$0.00
SANITARY SEWER SUBTOTAL					\$3,800.00		\$3,800.00		\$0.00		\$0.00
TOTAL ESTIMATED CONSTRUCTION COST					\$139,140.00		\$70,183.00		\$68,957.00		\$68,957.00
5% PROJECT CONTINGENCY					\$6,957.00		\$3,509.15		\$3,447.85		\$3,447.85
PROJECT RELATED COSTS					\$25,500.00		\$13,000.00		\$12,500.00		\$12,500.00
TOTAL ESTIMATED PROJECT COST					\$171,597.00		\$86,692.15		\$84,904.85		\$84,904.85

**CITY OF HAMBURG, MINNESOTA
RESOLUTION NUMBER 2022-06**

**RESOLUTION APPROVING PLANS AND SPECIFICATIONS
AND ORDERING ADVERTISEMENT FOR BIDS FOR THE
2022 STREET IMPROVEMENT PROJECT**

WHEREAS, the Hamburg City Council at the February 8, 2022 City Council Meeting ordered Short Elliot Hendrickson Inc. (SEH) to prepare plans and specifications for the construction of the 2022 Street Improvement Project;

WHEREAS, the consulting engineers (SEH) have prepared final plans and specifications for the construction of the 2022 Street Improvement Project in the City, and such plans and specifications have been presented to the City Council for approval:

NOW THEREFORE, BE IT RESOLVED, by the City Council of Hamburg, Minnesota as follows:

1. Such plans and specifications, a copy of which is attached hereto and made a part hereof, are hereby approved and ordered placed on file in the office of the City Clerk.
2. The City Clerk/Treasurer shall prepare and cause to be inserted in the official paper an advertisement for bids upon the making of such improvement under such approved plans and specifications. The advertisement shall be published as required by law, shall specify the work to be done, and shall state that online bids will be received by the City Clerk/Treasurer until 10:00 a.m. on Wednesday, April 27, 2022, at which time they will be publicly opened and read aloud via Microsoft Teams by the City Clerk/Treasurer and engineer, will then be tabulated, and will be considered by the council at 7:00 p.m. on Tuesday, May 10, 2022, in the council chambers of the Hamburg City Hall. Any bidder whose responsibility is questioned during consideration of the bid will be given an opportunity to address the council on the issue of responsibility. No bids will be considered unless sealed and filed with the City Clerk/Treasurer and accompanied by a cashier's check, bid bond, or certified check payable to the clerk for 5 percent of the amount of such bid.

I CERTIFY THAT the above resolution was adopted by the City Council of Hamburg, Carver County, Minnesota this 22nd day of March, 2022.

Chris Lund, Mayor

ATTEST:

Jeremy Gruenhagen, City Clerk/Treasurer

